

DaqBoard/2000 and /2000c Series User's Manual

For PCI-bus & Compact PCI-bus Data Acquisition Boards



the smart approach to instrumentation™

IOtech, Inc.

25971 Cannon Road

Cleveland, OH 44146-1833

Phone: (440) 439-4091

Fax: (440) 439-4093

E-mail (Product Information): sales@iotech.com

E-mail (Technical Support): productsupport@iotech.com

Internet: www.iotech.com

DaqBoard/2000 & /2000c Series User's Manual

*For PCI-bus & Compact PCI-bus
Data Acquisition Boards*

p/n 1033-0901 Rev. 4.0

Warranty Information

Your IOtech warranty is as stated on the *product warranty card*. You may contact IOtech by phone, fax machine, or e-mail in regard to warranty-related issues.

Phone: (440) 439-4091, fax: (440) 439-4093, e-mail: sales@iotech.com

Limitation of Liability

IOtech, Inc. cannot be held liable for any damages resulting from the use or misuse of this product.

Copyright, Trademark, and Licensing Notice

All IOtech documentation, software, and hardware are copyright with all rights reserved. No part of this product may be copied, reproduced or transmitted by any mechanical, photographic, electronic, or other method without IOtech's prior written consent. IOtech product names are trademarked; other product names, as applicable, are trademarks of their respective holders. All supplied IOtech software (including miscellaneous support files, drivers, and sample programs) may only be used on one installation. You may make archival backup copies.

FCC Statement



IOtech devices emit radio frequency energy in levels compliant with Federal Communications Commission rules (Part 15) for Class A devices. If necessary, refer to the FCC booklet *How To Identify and Resolve Radio-TV Interference Problems* (stock # 004-000-00345-4) which is available from the U.S. Government Printing Office, Washington, D.C. 20402.

CE Notice



Many IOtech products carry the CE marker indicating they comply with the safety and emissions standards of the European Community. As applicable, we ship these products with a Declaration of Conformity stating which specifications and operating conditions apply.

Warnings, Cautions, Notes, and Tips



Refer all service to qualified personnel. This caution symbol warns of possible personal injury or equipment damage under noted conditions. Follow all safety standards of professional practice and the recommendations in this manual. Using this equipment in ways other than described in this manual can present serious safety hazards or cause equipment damage.



This warning symbol is used in this manual or on the equipment to warn of possible injury or death from electrical shock under noted conditions.



This ESD caution symbol urges proper handling of equipment or components sensitive to damage from electrostatic discharge. Proper handling guidelines include the use of grounded anti-static mats and wrist straps, ESD-protective bags and cartons, and related procedures.



This symbol indicates the message is important, but is not of a Warning or Caution category. These notes can be of great benefit to the user, and should be read.



In this manual, the book symbol always precedes the words "Reference Note." This type of note identifies the location of additional information that may prove helpful. References may be made to other chapters or other documentation.



Tips provide advice that may save time during a procedure, or help to clarify an issue. Tips may include additional reference.

Specifications and Calibration

Specifications are subject to change without notice. Significant changes will be addressed in an addendum or revision to the manual. As applicable, IOtech calibrates its hardware to published specifications. Periodic hardware calibration is not covered under the warranty and must be performed by qualified personnel as specified in this manual. Improper calibration procedures may void the warranty.

Quality Notice



IOtech has maintained ISO 9001 certification since 1996. Prior to shipment, we thoroughly test our products and review our documentation to assure the highest quality in all aspects. In a spirit of continuous improvement, IOtech welcomes your suggestions.

Your order was carefully inspected prior to shipment. When you receive your system, carefully unpack all items from the shipping carton and check for physical signs of damage that may have occurred during shipment. Promptly report any damage to the shipping agent and your sales representative. Retain all shipping materials in case the unit needs returned to the factory.

CAUTION



Using this equipment in ways other than described in this manual can cause personal injury or equipment damage. Before setting up and using your equipment, you should read *all* documentation that covers your system. Pay special attention to Warnings and Cautions.

Note: During software installation, Adobe® PDF versions of user manuals will automatically install onto your hard drive as a part of product support. The default location is in the **Programs** directory, which can be accessed from the *Windows Desktop*. Refer to the PDF documentation for details regarding both hardware and software.

A copy of the Adobe Acrobat Reader® is included on your CD. The Reader provides a means of reading and printing the PDF documents. Note that hardcopy versions of the manuals can be ordered from the factory.



PDF
1033-0901

DaqBoard 2000 Series & DaqBoard/2000c Series User's Manual

Contains the DaqBoard/2000 Series and cPCI DaqBoard/2000c Series hardware-related and software-related chapters, as well as links to the .pdf files listed below. This pdf file, plus the following constitute a complete set of documentation for the DaqBoard/2000 Series boards and the cPCI DaqBoard/2000c Series boards. Note that the Programmer's Manual (1008-0901) and the DBK Option Cards & Modules (457-0905) are completely separate documents.



PDF
457-0909

DaqView and DaqViewXL

Discusses how to install and use these “out-of-the-box” data acquisition programs.



PDF

Post Acquisition Data Analysis User's Guide

Contains at least one user's guide that pertains to a post acquisition-data analysis program. PostView, DIAdem, and eZ-View are examples of post data analysis programs.



PDF
457-0905

DBK Option Cards and Modules User's Manual

The DBK Option Cards and Modules Manual discusses each of the DBK products available at the time of print.



PDF
1008-0901

Programmer's Manual

The programmer's manual pertains to developing custom programs using Applications Program Interface (API) commands.

Programmers should check the **readme.file** on the install CD-ROM for the location of program examples included on the CD.

Manual Layout

Note: For benefit of those who have not yet installed their DaqBoard/2000 Series or DaqBoard/2000c Series board, this manual begins with copies of the installation guides that are shipped with those products. Use the applicable guide to install the associated software, product support, and board.

DaqBoard/2000 Series, Installation Guide (p/n 1033-0940)

DaqBoard/2000c Series, Installation Guide (p/n 1061-0940)

Chapter 1 – Daq Systems and DaqBoard/2000 Series Devices. This chapter begins with a discussion of the “modular concept” that is associated with Daq data acquisition systems. The chapter then goes on to provide an overview for each DaqBoard/2000 Series and /2000c Series board.

DBK Basics (A Document Module) - discusses option cards and modules (DBKs) that can be used to enhance and expand data acquisition systems. Note that *DBK Basics* is not a chapter, but an independent document module that is applicable to this user’s manual, as well as others.

Chapter 2 – System Connections and Pinouts - This chapter provides an overview of the DBK200 Series P4 adapters that can be used, for example, to obtain DB37 type connectors (P1, P2, and P3) from the DaqBoard’s 100-pin P4 connector. Pinouts for P1, P2, P3, and P4 are included.

Chapter 3 - CE Compliance pertains to CE standards and conditions that are relevant to DaqBoard/2000 and DaqBoard/2000c Series boards. The appendix includes CE Kit installation instructions for both types of board.

Chapter 4 - Calibration lists the order in which to perform calibration-related adjustments and briefly discusses *DaqCal.exe*, a program that provides on-screen instruction, graphics, and prompts.

Glossary



Reference Notes:

During software installation, Adobe® PDF versions of user manuals are automatically installed onto your hard drive as a part of product support. The default location is in the **Programs** directory, which can be accessed from the Windows Desktop.

A copy of the Adobe Acrobat Reader® is included on your CD. The Reader provides a means of reading and printing the PDF documents. Note that hardcopy versions of manuals can be ordered from the factory.

- *DaqView and DaqViewXL* – explains the use and features of the included *out-of-the-box* data acquisition software.
- *Post Acquisition Data Analysis User’s Guide* – contains one or more document modules pertaining to a post-acquisition analysis program. Examples of such programs are PostView, DIAdem and eZ-View.
- For detailed information regarding specific DBKs, refer to the *DBK Option Cards and Modules User’s Manual*, p/n 457-0905. Each DBK section includes device-specific hardware and software information. The document includes a chapter on power management.
- For programming-related information refer to the separate *Programmer’s Manual*, p/n 1008-0901.

Table of Contents

DaqBoard/2000 Series, Installation Guide (p/n 1033-0940)
DaqBoard/2000c Series, Installation Guide (p/n 1061-0940)

1 – Daq Systems and Device Overviews

<i>Daq Systems, the Modular Concept</i>	<i>1-1</i>
<i>DaqBooks, DaqBoards, & Daq PC-Cards.....</i>	<i>1-2</i>
<i>Theory of Operation, DaqBoard/2000 Series and /2000c Series Boards</i>	<i>1-4</i>
<i>DaqBoard/2000 and/ 2000c.....</i>	<i>1-9</i>
<i>DaqBoard/2001 and /2001c</i>	<i>1-11</i>
<i>DaqBoard/2002 and /2002c</i>	<i>1-13</i>
<i>DaqBoard/2003 and /2003c</i>	<i>1-15</i>
<i>DaqBoard/2004 and /2004c</i>	<i>1-17</i>
<i>DaqBoard/2005 and /2005c</i>	<i>1-19</i>
<i>Using DBK Cards & Modules for Signal Conditioning</i>	<i>1-21</i>
<i>Daq Software</i>	<i>1-21</i>
<i>Specifications – DaqBoard/2000 Series and /2000c Series Boards</i>	<i>1-23</i>

DBK Basics (Document Module)

<i>Introduction.....</i>	<i>1</i>
<i>How Do DBKs Connect to the Data Acquisition Device?</i>	<i>2</i>
Connecting DBKs to DaqBooks, ISA-Type DaqBoards, and LogBooks	2
Connecting DBKs to Daq PC-Cards	3
Connecting DBKs to DaqBoard/2000 Series and cPCI DaqBoard/2000c Series Boards	4
<i>DBK Identification Tables</i>	<i>5</i>
Analog Output DBKs	5
Digital I/O Control DBKs	5
Analog Signal Conditioning DBKs	5
Expansion and Terminal Panel Connection DBKs	6
Power Supply DBKs	6
<i>Tips on Setting up a Data Acquisition System</i>	<i>7</i>
<i>Power Supplies and Power Connectors</i>	<i>8</i>
<i>An Introduction to Power-Related DBKs</i>	<i>9</i>
<i>Calculating Your System's Power Needs</i>	<i>11</i>
<i>Additional Reading</i>	<i>13</i>

2 – System Connections and Pinouts

<i>Overview</i>	<i>2-1</i>
<i>DBK200 Series, P4 Connector Options</i>	<i>2-2</i>
<i>Pinouts for DaqBoard/2000 Series and /2000c Series Boards</i>	<i>2-7</i>

3 - CE-Compliance

<i>Overview</i>	<i>3-1</i>
<i>CE Standards and Directives</i>	<i>3-1</i>
<i>Safety Conditions</i>	<i>3-2</i>
<i>Emissions/Immunity Conditions</i>	<i>3-2</i>
<i>CE Enhancements for DBKs ...</i>	<i>3-3</i>
<i>CE Cable Kits for DaqBoard 2000 Series and /2000c Series Boards.....</i>	<i>3-3</i>

4 – Calibration

Glossary

DaqBoard/2000 Series

PCI Data Acquisition Boards

Installation Guide

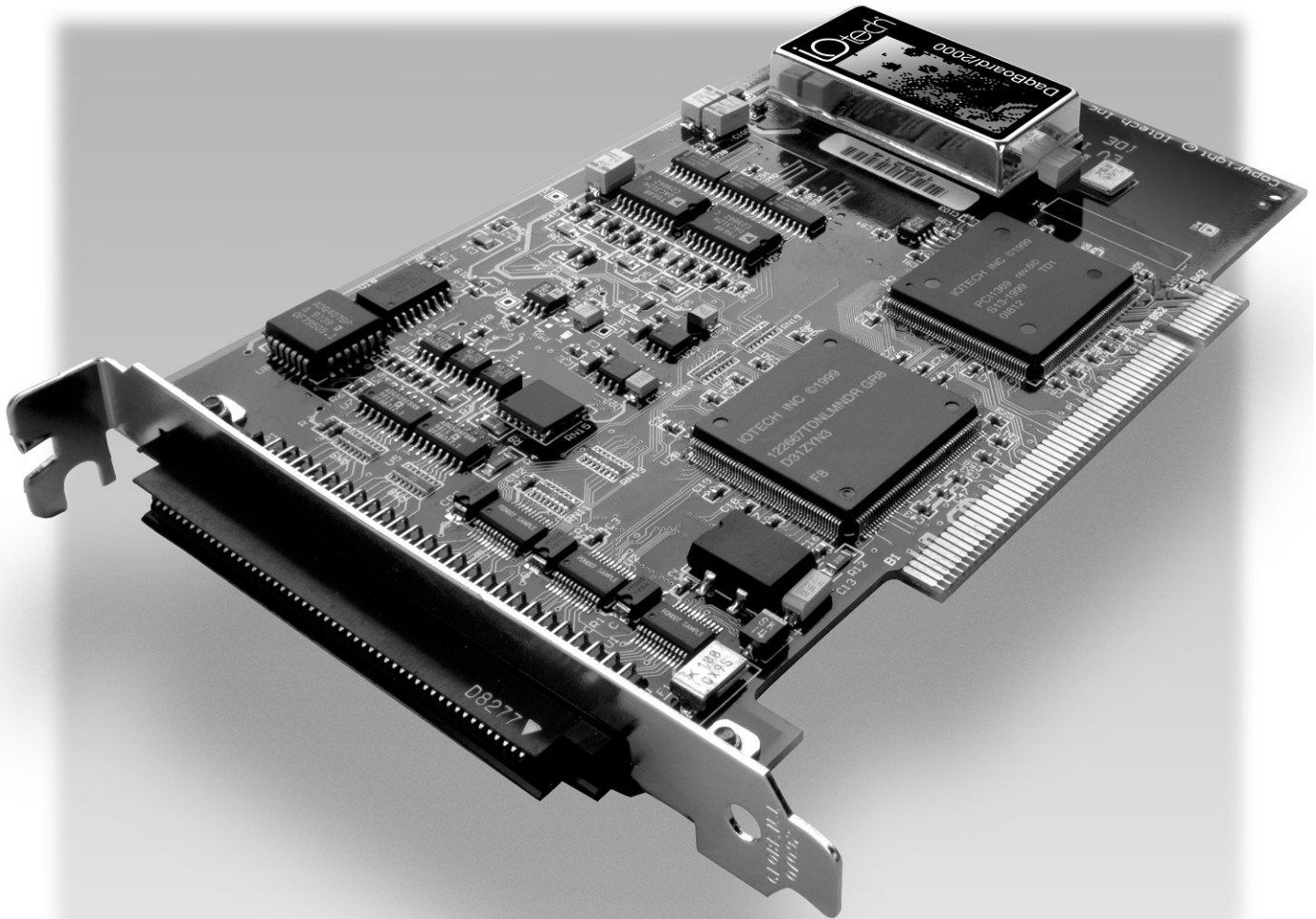

Iotech, Inc.
25971 Cannon Road
Cleveland, OH 44146
Ph: 440.439.4091
Fx: 440.439.4093

E-mail (Product Information): sales@iotech.com
E-mail (Technical Support): productsupport@iotech.com
Internet: www.iotech.com

Warranty Information

Your IOtech warranty is as stated on the *product warranty card*. You may contact IOtech by phone, fax machine, or e-mail in regard to warranty-related issues.

Phone: (440) 439-4091, fax: (440) 439-4093, e-mail: sales@iotech.com

Limitation of Liability

IOtech, Inc. cannot be held liable for any damages resulting from the use or misuse of this product.

Copyright, Trademark, and Licensing Notice

All IOtech documentation, software, and hardware are copyright with all rights reserved. No part of this product may be copied, reproduced or transmitted by any mechanical, photographic, electronic, or other method without IOtech's prior written consent. IOtech product names are trademarked; other product names, as applicable, are trademarks of their respective holders. All supplied IOtech software (including miscellaneous support files, drivers, and sample programs) may only be used on one installation. You may make archival backup copies.

FCC Statement



IOtech devices emit radio frequency energy in levels compliant with Federal Communications Commission rules (Part 15) for Class A devices. If necessary, refer to the FCC booklet *How To Identify and Resolve Radio-TV Interference Problems* (stock # 004-000-00345-4) which is available from the U.S. Government Printing Office, Washington, D.C. 20402.

CE Notice



Many IOtech products carry the CE marker indicating they comply with the safety and emissions standards of the European Community. As applicable, we ship these products with a Declaration of Conformity stating which specifications and operating conditions apply.

Warnings, Cautions, Notes, and Tips



Refer all service to qualified personnel. This caution symbol warns of possible personal injury or equipment damage under noted conditions. Follow all safety standards of professional practice and the recommendations in this manual. Using this equipment in ways other than described in this manual can present serious safety hazards or cause equipment damage.



This warning symbol is used in this manual or on the equipment to warn of possible injury or death from electrical shock under noted conditions.



This ESD caution symbol urges proper handling of equipment or components sensitive to damage from electrostatic discharge. Proper handling guidelines include the use of grounded anti-static mats and wrist straps, ESD-protective bags and cartons, and related procedures.



This symbol indicates the message is important, but is not of a Warning or Caution category. These notes can be of great benefit to the user, and should be read.



In this manual, the book symbol always precedes the words "Reference Note." This type of note identifies the location of additional information that may prove helpful. References may be made to other chapters or other documentation.



Tips provide advice that may save time during a procedure, or help to clarify an issue. Tips may include additional reference.

Specifications and Calibration

Specifications are subject to change without notice. Significant changes will be addressed in an addendum or revision to the manual. As applicable, IOtech calibrates its hardware to published specifications. Periodic hardware calibration is not covered under the warranty and must be performed by qualified personnel as specified in this manual. Improper calibration procedures may void the warranty.

Quality Notice



IOtech has maintained ISO 9001 certification since 1996. Prior to shipment, we thoroughly test our products and review our documentation to assure the highest quality in all aspects. In a spirit of continuous improvement, IOtech welcomes your suggestions.

During software installation, Adobe® PDF versions of user manuals are automatically installed onto your hard drive as a part of product support. The default location is in the **Programs** directory, which can be accessed from the Windows Desktop. A copy of the Adobe Acrobat Reader® is included on your CD. The Reader provides a means of reading and printing the PDF documents. Note that hardcopy versions of manuals can be ordered from the factory.

DaqBoard/2000 Series, Installation

This guide tells you how to complete the following steps for a successful installation.

Step 1 – Install Software page 4

Step 2 – Install Boards in Available PCI Bus-Slots page 5

Step 3 – Configure Boards page 7

Step 4 – Test Hardware page 8



Reference Note:

After you have completed the installation you should refer to the electronic documents that were automatically installed onto your hard drive as a part of product support. The default location is in the **Programs** directory, which can be accessed from the Windows Desktop.

You should keep your DaqBoard/2000 Series board's serial number and your DaqView/2000 authorization code (if applicable) with this document. Space is provided below for recording up to 4 board numbers and their PCI bus-slot location. The board serial number is located on the P4 connector as indicated in the following figure.

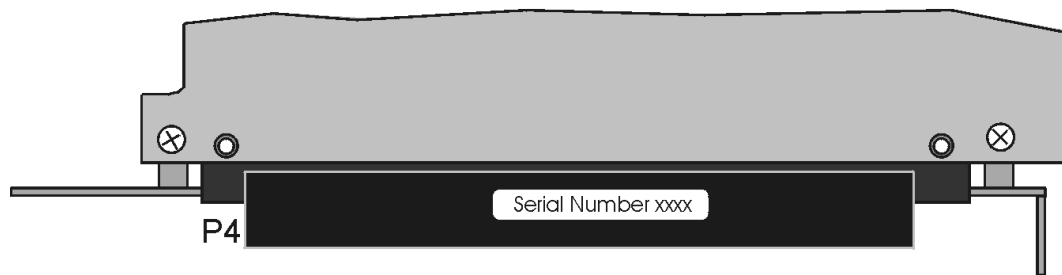

Serial Number Location on DaqBoard/2000 Series P4 Connector

	Board Type (e.g., 2000, 2002, 2003, etc.)*	Serial Number	PCI Bus-Slot Location
Board 1			
Board 2			
Board 3			
Board 4			

The host PC can support up to four DaqBoard/2000 Series Boards.

***Note:** DaqBoard/2000 Series boards have device labels which read, for example, "DaqBoard/2000," "DaqBoard/2001," "DaqBoard/2002," etc. The name labels are convenient for users of more than one board type.

DaqView/2000 Authorization Code _____

Customers who ordered DaqView/2000 can find their authorization code on the *authorization code sheet* located inside the sleeve of the install CD. Note that earlier documents may refer to this as a "registration code" or "registration ID."

Customers who did not order DaqView/2000 can run a *30-day free trial version*, as discussed elsewhere in the User's Manual.

CAUTION



Take ESD precautions (packaging, proper handling, grounded wrist strap, etc.)

Use care to avoid touching board surfaces and onboard components. Only handle boards by their edges (or ORBs, if applicable). Ensure boards do not come into contact with foreign elements such as oils, water, and industrial particulate.



Reference Notes:

- (1) Each DaqBoard/2000 Series Board plugs into a PCI bus-slot. Consult your PC owner's manual as needed.
- (2) Be sure to read about the DBK cards and modules applicable to your acquisition system. Specific DBK information can be found in on the world wide web at <http://www.daqboard.com>; and in your *DBK Option Cards and Modules User's Manual* (p/n 457-0905). After the install you can navigate to the DBK manual and other relevant electronic documents from your desktop as follows:

Start ⇒ Programs ⇒ Iotech DaqX Software ⇒ DaqBoard 2000 Series Users

Step 1 – Install Software



IMPORTANT: Software must be installed before installing hardware.

1. Place the Data Acquisition Software CD in the host PC's CD-ROM drive and wait for the PC to auto-access the CD. *If auto-access is disabled, run Setup.exe using Windows Run application from the desktop.*

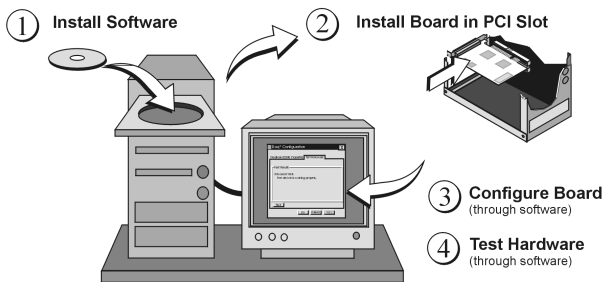

*DaqBoard/2000 Series Installation,
A Pictorial Overview*

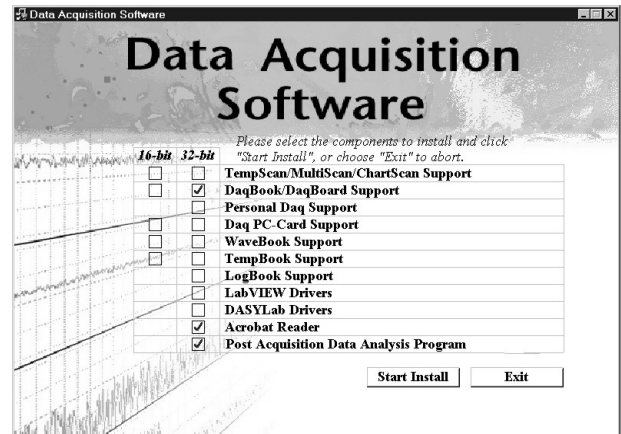

*Selecting 32-Bit DaqBook/DaqBoard Support,
Acrobat Reader, and a Post Acquisition Data
Analysis Program*

2. After the Data Acquisition Software *Master Setup* screen appears, select **32-bit** for **DaqBook/DaqBoard Support**.
3. *If you do not have Acrobat Reader version 4.0 or greater installed on your PC, select **Acrobat Reader**.* This will enable you to read and print documentation that is included on the install CD-ROM.
4. If you want to download the **Post Acquisition Data Analysis Program**, check the associated box. DIAdem, PostView, and eZ-View are examples of Post Acquisition Data Analysis programs. A copy of the applicable document will be placed in the **Programs** directory of your hard drive during the installation process. Note that you can download the post analysis program at a later time, if desired.
5. Click “**Start Install.**”
6. *If you get the following message:*

**“Setup detected previously installed components.
Would you like to exit setup now and uninstall the previous installation manually?”**

Select “**Yes**” and use Microsoft’s *Add/Remove Programs* feature to remove *any previous* version of Iotech DaqX software. This procedure is detailed in steps A through F of the following figure.

Screen images may vary from those depicted, depending on your operating system.

Note that previously installed versions of DaqView will be listed as

IOtech DaqX Software.

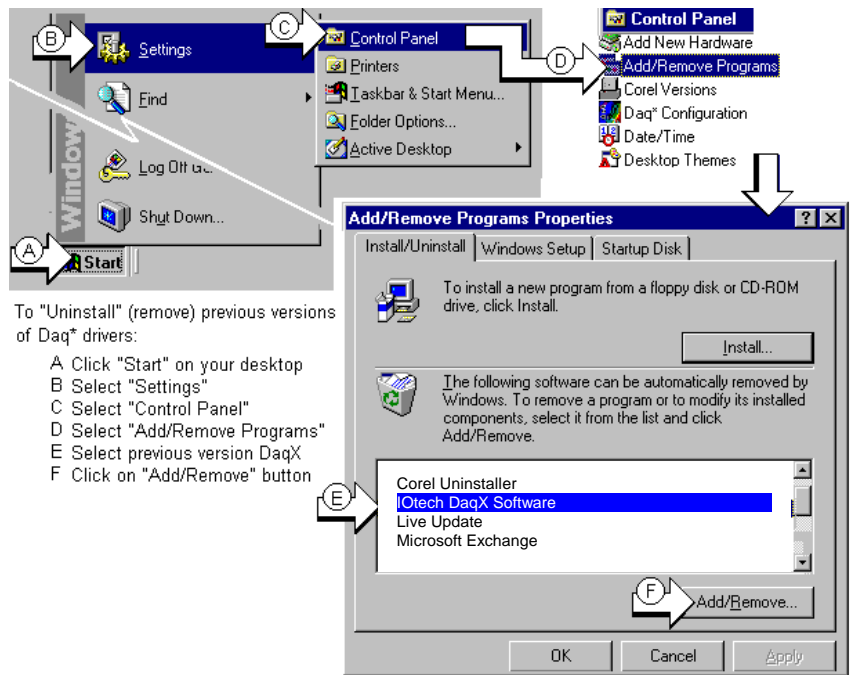

Removing Previous IOtech DaqX Software

Note: If you receive a message regarding *shared files*, read the message before selecting a provided option button. If you are not sure what to do after reading the message, select the "No to All" option.

7. After removing previous versions (if applicable), click **OK** and exit the Control Panel.
8. Eject, then reinsert the Install CD; then wait for Auto-Access. The install should take place automatically. If *auto-access is disabled*, run **Setup.exe** using Windows Run application from the desktop.

Note: If you receive a message during the software install stating that the DaqBoard device is *not detected*, click "**OK**."

9. When install is complete select the radio button for the "**Exit viewing Readme file**" option. This file contains important information that may not be available elsewhere.
10. After reviewing the **Readme** file, exit the program.
11. Remove the CD.
12. Shutdown the PC.

You are now ready to install your PCI board(s) as discussed in the following section.

Step 2 – Install Boards in available PCI Bus-slots



IMPORTANT: Software must be installed before installing hardware.



IMPORTANT: Bus Mastering DMA *must be Enabled*.

For a DaqBoard/2000 Series board to operate properly, Bus Mastering DMA *must be enabled*. Prior to installation, verify that your computer is capable of performing Bus Mastering DMA for the applicable PCI bus-slot. Note that some computers have BIOS settings that enable [or disable] Bus Mastering DMA. If your computer has this BIOS option, ensure that Bus Mastering DMA is *Enabled* on the appropriate PCI slot.

Refer to your PC's owner manual for additional information regarding Bus Mastering DMA.

CAUTION



Turn off power to, and **UNPLUG** the host PC and externally connected equipment prior to removing the PC's cover and installing DaqBoard/2000. Electric shock or damage to equipment can result even under low-voltage conditions.



Take ESD precautions (packaging, proper handling, grounded wrist strap, etc.)

Use care to avoid touching board surfaces and onboard components. Only handle boards by their edges (or ORBs, if applicable). Ensure boards do not come into contact with foreign elements such as oils, water, and industrial particulate.



IMPORTANT: Bus Mastering DMA *must be Enabled*.

For a DaqBoard/2000 Series board to operate properly, Bus Mastering DMA *must be Enabled* on the PCI slot [for which the DaqBoard/2000 Series board is to be installed]. Prior to installation, verify that your computer is capable of performing Bus Mastering DMA for the applicable PCI slot. Note that some computers have BIOS settings that enable [or disable] Bus Mastering DMA. If your computer has this BIOS option, ensure that Bus Mastering DMA is *Enabled* on the appropriate PCI slot.

Refer to your PC Owner's Manual for additional information regarding your PC and enabling Bus Mastering DMA for PCI slots.

1. Turn **off** power to, and **UNPLUG the host PC** and externally connected equipment.
2. Remove the PC's cover. *Refer to your PC Owner's Manual as needed.*
3. Choose an available PCI bus-slot.
4. Carefully remove DaqBoard/2000 Series Board from its anti-static protective bag. If you have not already done so, write down the serial number of your board at this time. See inside front cover for details.
5. On the PC's rear panel, loosen and remove the screw for the blank adapter plate that corresponds with the chosen PCI bus.
6. Remove the adapter plate for the chosen PCI slot.
Refer to your PC Owner's Manual if needed.
7. Align groove in the DaqBoard/2000 Series board's PCI edge-connector with the ridge of the desired PCI slot, and with the PC's corresponding rear-panel slot.
8. Push the board firmly into the PCI slot. The board will snap into position.
9. Secure the board by inserting the rear-panel adapter-plate screw.
10. Using the previous steps, install additional boards into available PCI bus-slots, if applicable to your application.
11. Replace the computer's cover.
12. Plug in all cords and cables that were removed in step 1.
13. Apply power to, and start up the PC.

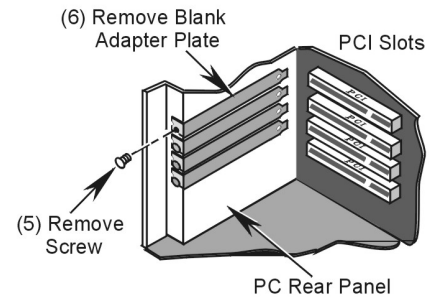

Removing a Blank Adapter Plate

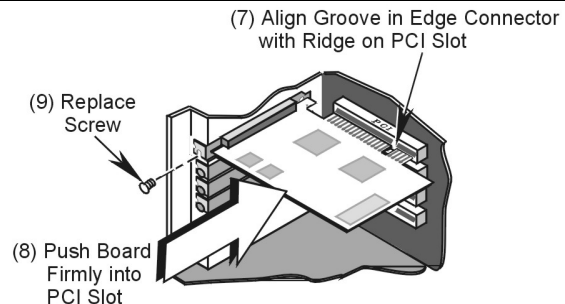

Installing a DaqBoard/2000 Series Board

Note: At this point some PCs may prompt you to insert an installation disk. While this is rare, if you do receive such a prompt simply place the install CD-ROM into the disk drive and follow additional screen prompts.

Step 3 – Configure Boards

DaqBoard/2000 Series Boards have no jumpers or switches to set. Configuration is performed, in its entirety, through software. Refer to the following figure and steps to complete the configuration. The numbers in the figure correspond to the numbered steps immediately following the figure.

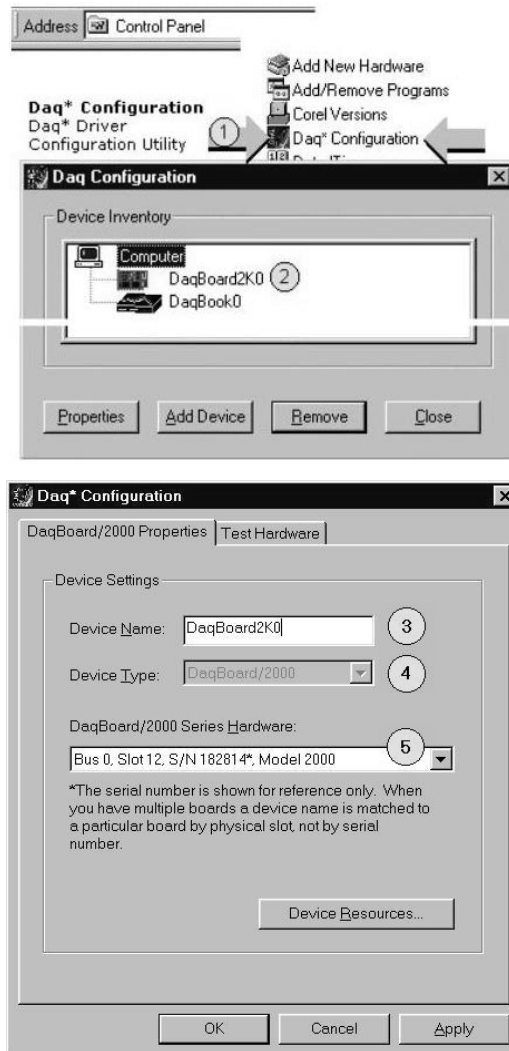

Accessing the DaqBoard/2000 Properties Tab

1. Run the **Daq Configuration** control panel applet. Navigation from the desktop to the applet is as follows: **Start ⇒ Settings ⇒ Control Panel ⇒ Daq*Configuration** (*double-click*)
2. Double-click on the Device Inventory's DaqBoard2K0 icon. The DaqBoard/2000 Properties tab (used for the entire DaqBoard/2000 Series) will appear. **If the DaqBoard2K0 icon is not present, skip to the Using 'Add Device' section provided below.**
3. Enter a "**Device Name**" in the text box, or use the default "DaqBoard2K0." Device Name is for identifying the specific DaqBoard/2000 Series board. Note that Device Name actually refers to the PCI slot and not to the actual board.
4. Verify that the "Device Type" shows the correct DaqBoard/2000 Series board, e.g., "DaqBoard/2000, DaqBoard/2001, etc." Note that available device types can be viewed via the pull-down list (▼).
5. Confirm that the DaqBoard/2000 Series text box shows a **Bus #, Slot #, and Serial Number**. **If this text box is empty**, use its pull-down list (▼) and select the serial number that matches the one for your board.

Refer to the inside front cover page for serial number information.

Using “Add Device”

This method is for users who have accessed the **Daq Configuration** control panel applet, but have no DaqBoard2K icon (as described on page 7, step 2).

- (A) After accessing the Daq Configuration control panel applet, click on the Add Device button (see figure, right). The *Select Device Type* window will appear.
- (B) Using the *Device Type*'s pull-down list, select the applicable board. In the example at the right **DaqBoard/2000** is selected.
- (C) Click the **OK** button. The DaqBoard/2000 Properties tab will appear. This tab applies to all boards in the DaqBoard/2000 Series.

At this point, complete steps 3 through 5 from page 7.

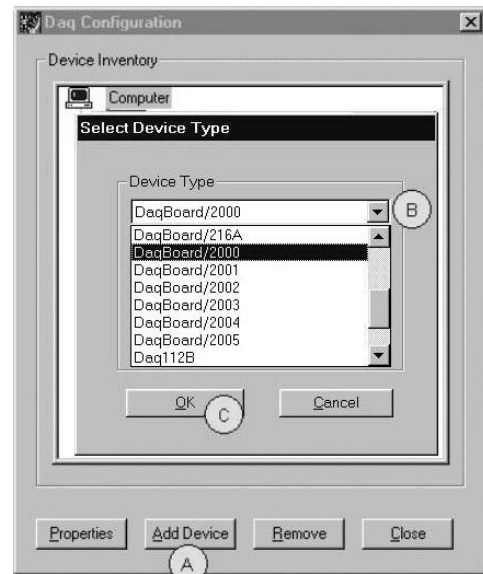

Using “Add Device”

Step 4 – Test Hardware

Use the following steps to test the DaqBoard/2000 Series board. Note that these steps are continued from those listed under the previous section, “Configure Board.”

1. Select the “**Test Hardware**” tab.
2. Click the “**Resource Test**” button.
3. After the test is complete, click “**OK**.”

System capability is now tested for the DaqBoard/2000 Series board and a list of test results appears on screen.

Note: If you experience difficulties, please consult your user documentation (included on your CD) before calling for technical support. Note that the user documentation includes a troubleshooting chapter, as well as a great deal of information regarding specific DBK cards and modules.

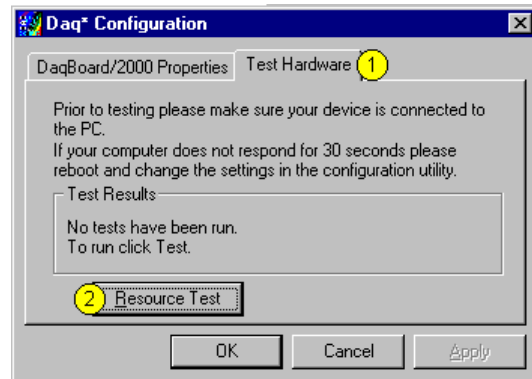

Test Hardware Tab
(Condensed Screen Image)

At this point we are ready to connect signals. This is typically accomplished with the use of a DBK200 Series option.



Reference Note:

For detailed information regarding the DBK200 Series options, refer to the *DBK Option Cards and Modules User's Manual* (p/n 457-0905).

During software installation, Adobe® PDF versions of user manuals are automatically installed onto your hard drive as a part of product support. The default location is in the **Programs** directory, which can be accessed from the Windows Desktop. A copy of the Adobe Acrobat Reader® is included on your CD. The Reader provides a means of reading and printing the PDF documents. Note that hardcopy versions of manuals can be ordered from the factory.

DaqBoard/2000c Series

Compact-PCI Data Acquisition Boards

Installation Guide

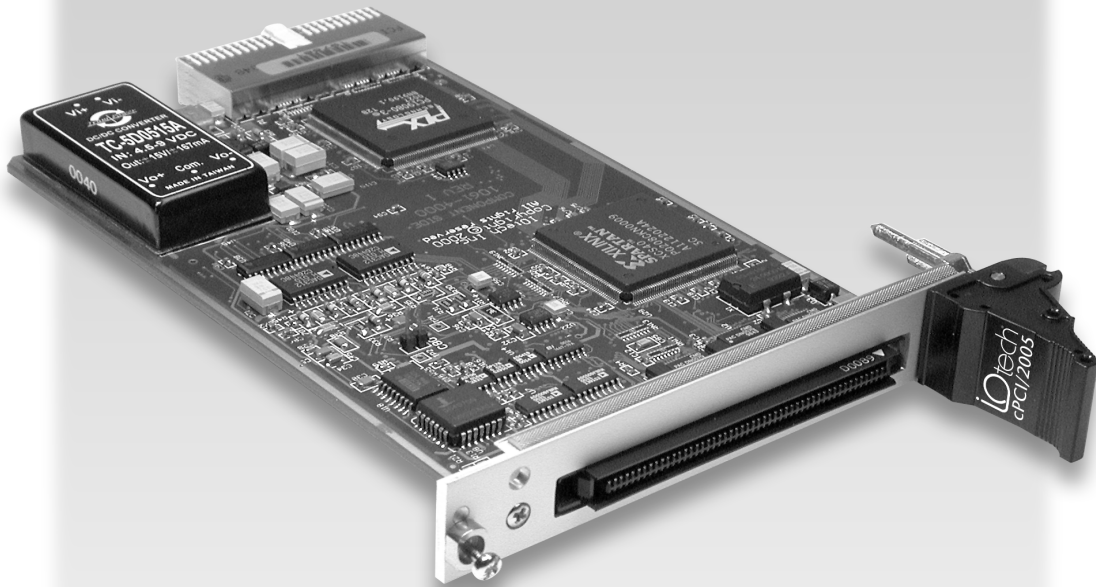

the smart approach to instrumentation™

Iotech, Inc.

25971 Cannon Road
Cleveland, OH 44146

Ph: (440) 439-4091

Fax: (440) 439-4093

E-mail (Product Information): sales@iotech.com

E-mail (Technical Support): productsupport@iotech.com

Internet: www.iotech.com

Warranty Information

Your IOtech warranty is as stated on the *product warranty card*. You may contact IOtech by phone, fax machine, or e-mail in regard to warranty-related issues.

Phone: (440) 439-4091, fax: (440) 439-4093, e-mail: sales@iotech.com

Limitation of Liability

IOtech, Inc. cannot be held liable for any damages resulting from the use or misuse of this product.

Copyright, Trademark, and Licensing Notice

All IOtech documentation, software, and hardware are copyright with all rights reserved. No part of this product may be copied, reproduced or transmitted by any mechanical, photographic, electronic, or other method without IOtech's prior written consent. IOtech product names are trademarked; other product names, as applicable, are trademarks of their respective holders. All supplied IOtech software (including miscellaneous support files, drivers, and sample programs) may only be used on one installation. You may make archival backup copies.

FCC Statement



IOtech devices emit radio frequency energy in levels compliant with Federal Communications Commission rules (Part 15) for Class A devices. If necessary, refer to the FCC booklet *How To Identify and Resolve Radio-TV Interference Problems* (stock # 004-000-00345-4) which is available from the U.S. Government Printing Office, Washington, D.C. 20402.

CE Notice



Many IOtech products carry the CE marker indicating they comply with the safety and emissions standards of the European Community. As applicable, we ship these products with a Declaration of Conformity stating which specifications and operating conditions apply.

Warnings, Cautions, Notes, and Tips



Refer all service to qualified personnel. This caution symbol warns of possible personal injury or equipment damage under noted conditions. Follow all safety standards of professional practice and the recommendations in this manual. Using this equipment in ways other than described in this manual can present serious safety hazards or cause equipment damage.



This warning symbol is used in this manual or on the equipment to warn of possible injury or death from electrical shock under noted conditions.



This ESD caution symbol urges proper handling of equipment or components sensitive to damage from electrostatic discharge. Proper handling guidelines include the use of grounded anti-static mats and wrist straps, ESD-protective bags and cartons, and related procedures.



This symbol indicates the message is important, but is not of a Warning or Caution category. These notes can be of great benefit to the user, and should be read.



In this manual, the book symbol always precedes the words "Reference Note." This type of note identifies the location of additional information that may prove helpful. References may be made to other chapters or other documentation.



Tips provide advice that may save time during a procedure, or help to clarify an issue. Tips may include additional reference.

Specifications and Calibration

Specifications are subject to change without notice. Significant changes will be addressed in an addendum or revision to the manual. As applicable, IOtech calibrates its hardware to published specifications. Periodic hardware calibration is not covered under the warranty and must be performed by qualified personnel as specified in this manual. Improper calibration procedures may void the warranty.

Quality Notice



IOtech has maintained ISO 9001 certification since 1996. Prior to shipment, we thoroughly test our products and review our documentation to assure the highest quality in all aspects. In a spirit of continuous improvement, IOtech welcomes your suggestions.

During software installation, Adobe® PDF versions of user manuals are automatically installed onto your hard drive as a part of product support. The default location is in the **Programs** directory, which can be accessed from the Windows Desktop. A copy of the Adobe Acrobat Reader® is included on your CD. The Reader provides a means of reading and printing the PDF documents. Note that hardcopy versions of manuals can be ordered from the factory.

This guide tells you how to complete the following steps for a successful installation.

Step 1 – Install Software page 4

Step 2 – Install Boards into Available, 5 Volt, Compact-PCI Bus-Slots page 5

Step 3 – Configure Boards page 7

Step 4 – Test Hardware page 8



Reference Note:

After you have completed the installation you should refer to the electronic documents that were automatically installed onto your hard drive as a part of product support. The default location is in the **Programs** directory, which can be accessed from the Windows Desktop.

You should keep your DaqBoard/2000c Series board’s serial number and your DaqView/2000 authorization code (if applicable) with this document. Space is provided below for recording up to 4 board numbers and their compact-PCI bus-slot location. Board serial numbers are located on the 100-pin P4 connector.

	Board Type e.g., DaqBoard/2005c	Serial Number	Compact-PCI Bus-Slot Location
Board 1			
Board 2			
Board 3			
Board 4			

Compact PC support for DaqBoard/2000c Series boards varies. A system can support no more than four boards.

***Note:** The DaqBoard/2000c Series boards have their board identity indicated on the latch, as indicated in the photo on the front page of this guide. This identification is provided since the boards look very much alike and are visually identical once installed.

DaqView/2000 Authorization Code _____

Customers who ordered DaqView/2000 can find their authorization code on the *authorization code sheet* located inside the sleeve of the install CD. Customers who did not order DaqView/2000 can run a *30-day free trial version*, as discussed in the user’s manual.

CAUTION



Take ESD precautions (packaging, proper handling, grounded wrist strap, etc.)

Use care to avoid touching board surfaces and onboard components. Only handle boards by their edges (or ORBs, if applicable). Ensure boards do not come into contact with foreign elements such as oils, water, and industrial particulate.



Reference Note:

During software installation, Adobe® PDF versions of user manuals are automatically installed onto your hard drive as a part of product support. The default location is in the **Programs** directory, which can be accessed from the Windows Desktop. A copy of the Adobe Acrobat Reader® is included on your CD. The Reader provides a means of reading and printing the PDF documents. Note that hardcopy versions of manuals can be ordered from the factory.

Note: In regard to functionality, the DaqBoard/2000c Series boards are identical to their DaqBoard/2000 Series counterparts.



Reference Notes:

- Each DaqBoard/2000c Series Board plugs into a 5 volt, compact-PCI bus-slot located on the PC's backplane. Note that the 5 V compact-PCI bus-slot contains a blue key (see page 6). Consult your PC owner's manual as needed.
- Be sure to read about the DBK cards and modules applicable to your acquisition system. Specific DBK information can be found in on the world wide web at <http://www.daqboard.com>; and in your *DBK Option Cards and Modules User's Manual* (p/n 457-0905). After the install you can navigate to the DBK manual and other relevant electronic documents from your desktop as follows:

Start ⇒ Programs ⇒ IOtech DaqX Software ⇒ DaqBoard 2000 Series Users

Step 1 – Install Software



IMPORTANT: Software must be installed before installing hardware.

1. Place the Data Acquisition Software CD in the host PC's CD-ROM drive and wait for the PC to auto-access the CD. *If auto-access is disabled*, run **Setup.exe** using Windows Run application from the desktop.
2. After the Data Acquisition Software *Master Setup* screen appears, select **32-bit** for **DaqBook/DaqBoard Support**.
3. *If you do not have Acrobat Reader version 4.0 or greater* installed on your PC, select **Acrobat Reader**. This will enable you to read and print documentation that is included on the install CD-ROM.

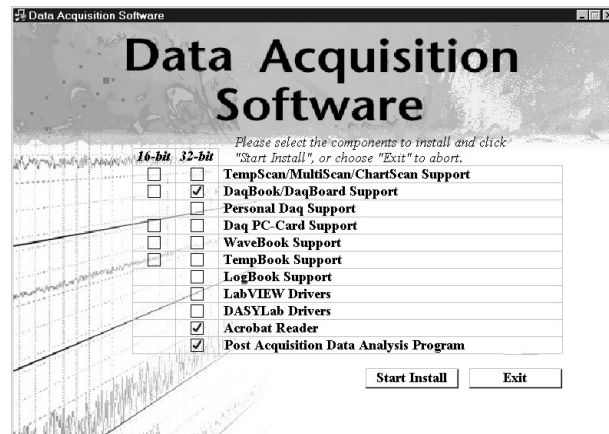

Selecting 32-Bit DaqBook/DaqBoard Support, Acrobat Reader, and a Post Acquisition Data Analysis Program

4. If you want to download the **Post Acquisition Data Analysis Program**, check the associated box. DIAdem, PostView, and eZ-View are examples of Post Acquisition Data Analysis programs. A copy of the applicable document will be placed in the **Programs** directory of your hard drive during the installation process. Note that you can download the post analysis program at a later time, if desired.
5. Click **“Start Install.”**
6. *If you get the following message:*

**“Setup detected previously installed components.
Would you like to exit setup now and uninstall the previous installation manually?”**

Select **“Yes”** and use Microsoft's *Add/Remove Programs* feature to remove *any previous* version of IOtech DaqX software. This procedure is detailed in steps A through F of the following figure.

Screen images may vary from those depicted, depending on your operating system.

Note that previously installed versions of DaqView will be listed as

IOtech DaqX Software.

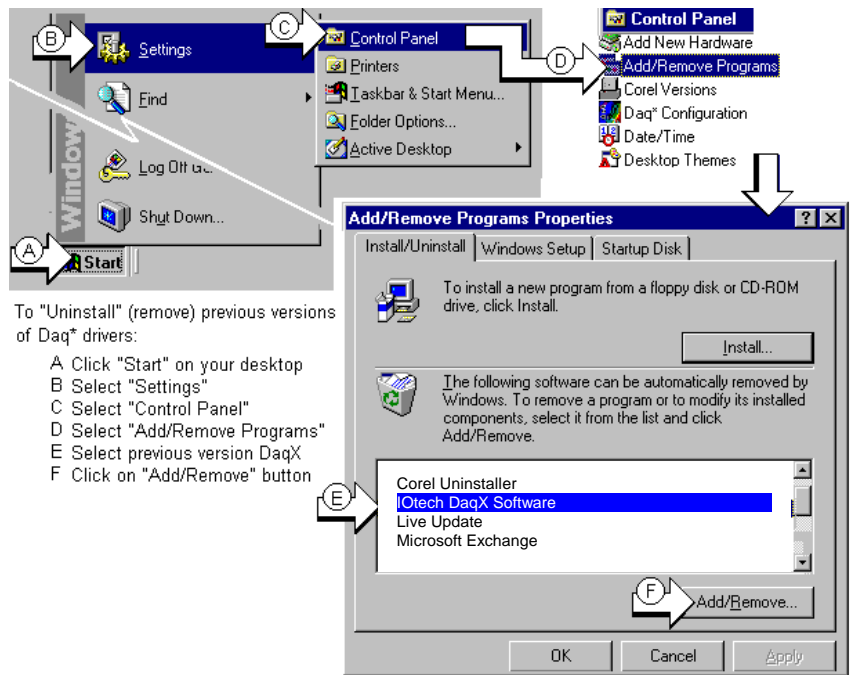

To "Uninstall" (remove) previous versions of Daq* drivers:

- A Click "Start" on your desktop
- B Select "Settings"
- C Select "Control Panel"
- D Select "Add/Remove Programs"
- E Select previous version DaqX
- F Click on "Add/Remove" button

Removing Previous IOtech DaqX Software

Note: If you receive a message regarding *shared files*, read the message before selecting a provided option button. If you are not sure what to do after reading the message, select the "No to All" option.

7. After removing previous versions (if applicable), click **OK** and exit the Control Panel.
8. Eject, then reinsert the Install CD; then wait for Auto-Access. The install should take place automatically. If *auto-access is disabled*, run **Setup.exe** using Windows Run application from the desktop.

Note: If you receive a message during the software install stating that the DaqBoard device is *not detected*, click "**OK**."

9. When install is complete select the radio button for the "**Exit viewing Readme file**" option. This file contains important information that may not be available elsewhere.
10. After reviewing the **Readme** file, exit the program.
11. Remove the CD.
12. Shutdown the PC.

You are now ready to install your compact-PCI board(s) as discussed in the following section.

Step 2 – Install Boards in available 5 Volt, Compact-PCI Bus-slots



IMPORTANT: Software must be installed before installing hardware.



IMPORTANT: Bus Mastering DMA *must be Enabled*.

For a DaqBoard/2000c Series board to operate properly, Bus Mastering DMA *must be enabled*. Prior to installation, verify that your computer is capable of performing Bus Mastering DMA for the applicable compact-PCI bus-slot. Note that some computers have BIOS settings that enable [or disable] Bus Mastering DMA. If your computer has this BIOS option, ensure that Bus Mastering DMA is *Enabled* on the appropriate compact-PCI bus-slot.

Refer to your PC's owner manual for additional information regarding Bus Mastering DMA.



IMPORTANT: The Compact-PCI Bus-Slot must be keyed for 5 Volt use.

Note: The 5 Volt Key location is indicated in the first photograph on page 6.

CAUTION



Turn power **OFF**, and **UNPLUG** the host PC and externally connected equipment prior to removing any cover plates or modules. Electric shock or damage to equipment can result even under low-voltage conditions.



Take ESD precautions (packaging, proper handling, grounded wrist strap, etc.)

Use care to avoid touching board surfaces and onboard components. Only handle boards by their edges or ORBs. Ensure boards do not come into contact with foreign elements such as oils, water, and industrial particulate.

1. Turn the PC's power **OFF**.
2. Turn **power OFF** to externally connected equipment.
3. **UNPLUG the host PC** and all externally connected equipment.
4. Remove the computer's compact-PCI bus-slot cover plate [or remove an unwanted module, if applicable]. Refer to your PC Owner's Manual as needed.
5. Verify that the available compact-PCI bus slot is for 5 volt applications.

The computer's 5 volt compact-PCI bus-slots can be recognized by a blue voltage key that is located in the center of the slot (see figure).

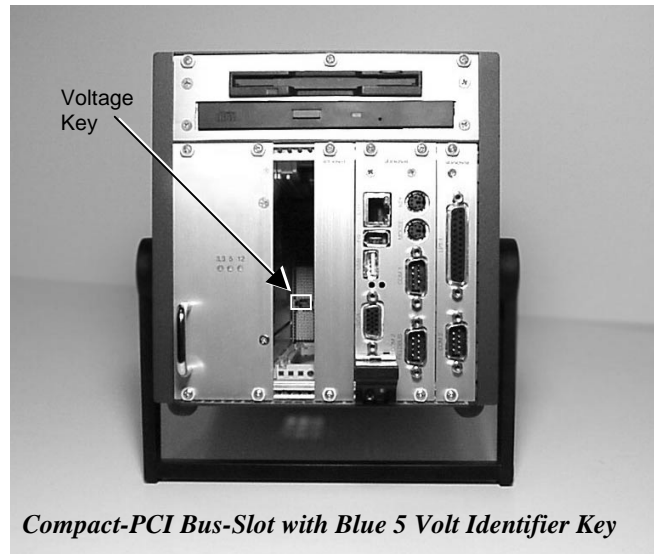

Compact-PCI Bus-Slot with Blue 5 Volt Identifier Key

6. Carefully remove the DaqBoard/2000c Series Board from its anti-static protective bag. If you have not already done so, write down the serial number of your board at this time. The serial number is located on the 100-pin P4 connector.
7. With the board's *injector/ejector* down, guide the board into the PC's slot. Note that the top and bottom edges of the board locate in edge-guides, within the PC.
8. Push the board back into the PC to engage the board's compact-PCI connector with the computer's compact-PCI bus-slot.
9. Pull the board's *injector/ejector* up. This will fully engage the connectors.
10. Secure the board by tightening the upper and lower lock screws.
11. Using the previous steps, install additional boards into available compact-PCI bus-slots, if applicable to your application.

Note: The lower lock screw is accessed through an opening on the *injector/ejector* as indicated in the right-hand figure.

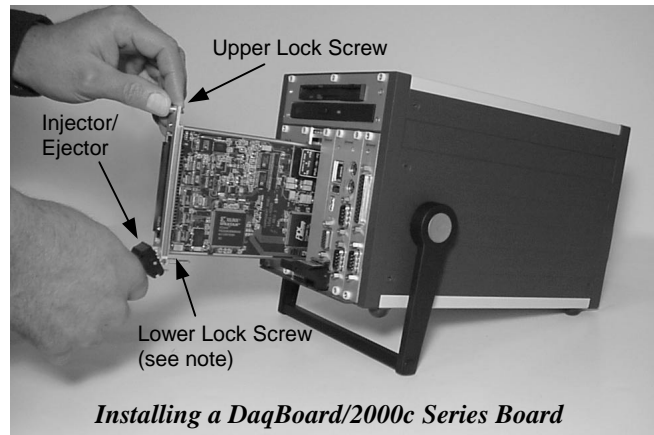

Installing a DaqBoard/2000c Series Board

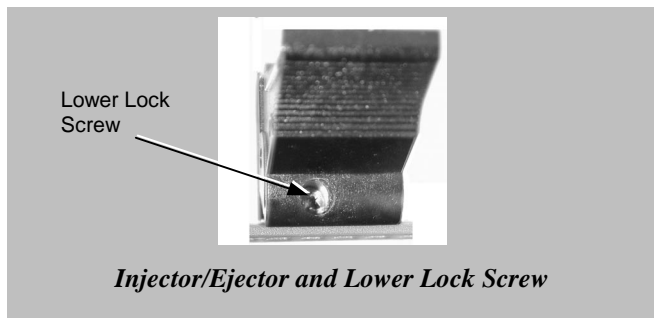

Injector/Ejector and Lower Lock Screw

12. Plug in all cords and cables that were removed in step 3.
13. Apply power to, and start up the PC.

Note: At this point some PCs may prompt you to insert an installation disk. While this is rare, if you do receive such a prompt simply place the install CD into the disk drive and follow the screen prompts.



Securing a DaqBoard/2000c Series Board

Step 3 – Configure Boards

DaqBoard/2000c Series boards have no jumpers or switches to set. Configuration is performed entirely through software. Refer to the following figure and steps to complete the configuration. The numbers in the figure correspond to the numbered steps immediately following the figure.

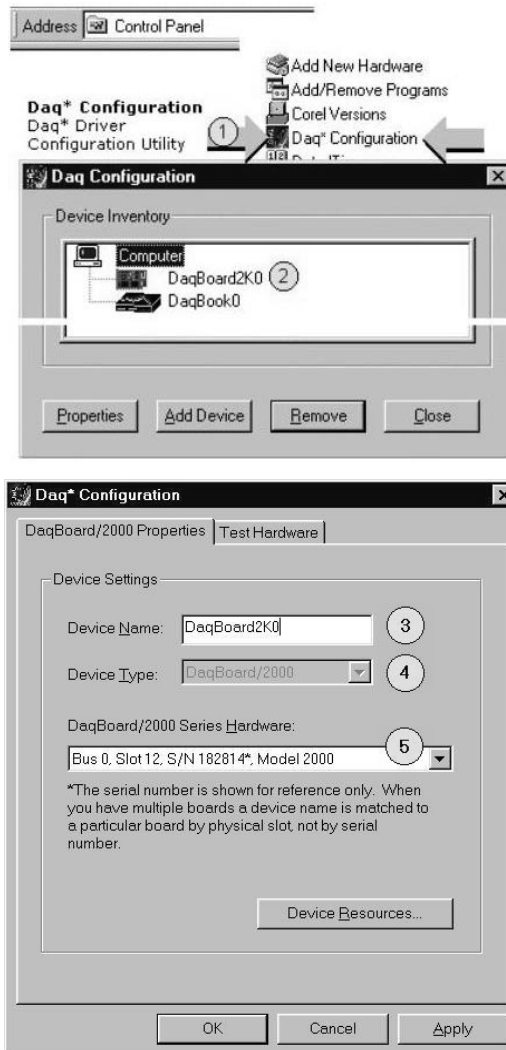

Accessing the DaqBoard/2000 Properties Tab

1. Run the **Daq Configuration** control panel applet. Navigation from the desktop to the applet is as follows:
Start ⇒ Settings ⇒ Control Panel ⇒ Daq*Configuration (*double-click*)
2. Double-click on the Device Inventory's DaqBoard2K0 icon. The DaqBoard/2000 Properties tab (used for the entire DaqBoard/2000 Series) will appear. **If the DaqBoard2K0 icon is not present, skip to the Using 'Add Device' section provided below.**
3. Enter a "**Device Name**" in the text box, or use the default "DaqBoard2K0." Device Name is for identifying the specific DaqBoard/2000 Series board. Note that Device Name actually refers to the PCI slot and not to the actual board.
4. Verify that the "Device Type" shows the correct DaqBoard/2000 Series board, e.g., "DaqBoard/2000, DaqBoard/2001, etc."
Note that available device types can be viewed via the pull-down list (▼).
5. Confirm that the DaqBoard/2000 Series text box shows a **Bus #, Slot #, and Serial Number**.
If this text box is empty, use its pull-down list (▼) and select the serial number that matches the one for your board. Refer to the inside front cover page for serial number information.

Using "Add Device"

This method is for users who have accessed the **Daq Configuration** control panel applet, but have no DaqBoard2K icon (as described in step 2, above).

- (A) After accessing the Daq Configuration control panel applet, click on the Add Device button (see figure, right). The *Select Device Type* window will appear.
- (B) Using the *Device Type's* pull-down list, select the applicable board. In the example at the right **DaqBoard/2000** is selected.
- (C) Click the **OK** button. The DaqBoard/2000 Properties tab will appear. This tab applies to all boards in the DaqBoard/2000 Series.
At this point, complete steps 3 through 5 from above.

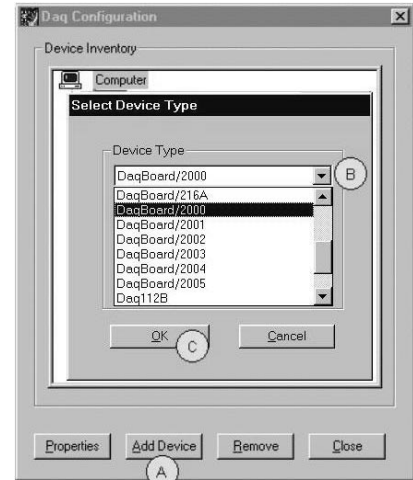

Using "Add Device"

Step 4 – Test Hardware

Use the following steps to test the DaqBoard/2000 Series board. Note that these steps are continued from those listed under the previous section, "Configure Board."

1. Select the "**Test Hardware**" tab.
2. Click the "**Resource Test**" button.
3. After the test is complete, click "**OK**."

System capability is now tested for the DaqBoard/2000 Series board and a list of test results appears on screen.

Note: If you experience difficulties, please consult your user documentation (included on your CD) before calling for technical support. Note that the user documentation includes a troubleshooting chapter, as well as a great deal of information regarding specific DBK cards and modules.

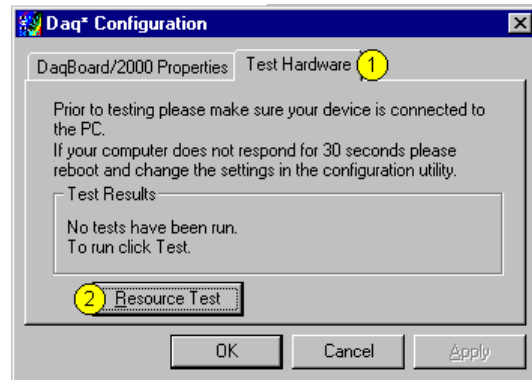

Test Hardware Tab (Condensed Screen Image)

At this point we are ready to connect signals. This is typically accomplished with the use of a DBK200 Series option.



Reference Note:

For detailed information regarding the DBK200 Series options, refer to the *DBK Option Cards and Modules User's Manual* (p/n 457-0905).

During software installation, Adobe® PDF versions of user manuals are automatically installed onto your hard drive as a part of product support. The default location is in the **Programs** directory, which can be accessed from the Windows Desktop. A copy of the Adobe Acrobat Reader® is included on your CD. The Reader provides a means of reading and printing the PDF documents. Note that hardcopy versions of manuals can be ordered from the factory.

- [Daq Systems, the Modular Concept 1-1](#)
- [DaqBooks, DaqBoards, and Daq PC-Cards 1-2](#)
- [Theory of Operation, DaqBoard/2000 Series and /2000c Series Boards 1-4](#)
- [DaqBoard/2000 and /2000c 1-9](#)
- [DaqBoard/2001 and /2001c..... 1-11](#)
- [DaqBoard/2002 and /2002c..... 1-13](#)
- [DaqBoard/2003 and /2003c..... 1-15](#)
- [DaqBoard/2004 and /2004c..... 1-17](#)
- [DaqBoard/2005 and /2005c..... 1-19](#)
- [Using DBK Cards and Modules for Signal Conditioning 1-21](#)
- [Daq Software1-21](#)
- [Specifications - DaqBoard/2000 Series and /2000c Series Boards..... 1-23](#)

Daq Systems, the Modular Concept

Daq equipment and software form a modular, interrelated family of products that provide great flexibility in data acquisition system design. This flexibility allows for the development of custom systems that are unique to the user, and which can be optimized for his or her specific application needs. With the Daq product line, system expansion or redesign can typically be accomplished with relative ease.

- **Primary Acquisition Device.** This is the main data acquisition device, e.g., a DaqBook, DaqBoard, or Daq PC-Card. These devices provide a vital data conversion and communications link between the data source of transducers and signal conditioners and the data processor of the host computer. Note the DaqBoards can be one of three types: (1) ISA, (2) PCI, or (3) compact-PCI.
- **DBK Option Cards and Modules.** Over 35 DBK cards and modules (the number is constantly growing) provide various types of signal conditioning and system expansion. Note that certain DBK modules exist for the purpose of supplying power to other members of the acquisition system. The DBK options are discussed in a [DBK Basics](#) document module and in the detailed [DBK Option Cards and User's Manual](#) (p/n 457-0905).

Note: Only *passive* DBKs, such as the DBK1 BNC module, the DBK11A screw terminal card, and the DBK40 BNC analog interface, can be used with a Daq PC-Cards.



Reference Note:

DBK options are discussed in the [DBK Option Cards and Modules User's Manual](#) (p/n 457-0905). As a part of product support, this manual is automatically loaded onto your hard drive during software installation. The default location is the Programs directory, which can be accessed through the Windows Desktop.

- **Software.** DaqView *out-of-the-box* software provides a graphical user interface with easy to read spreadsheet formats for viewing channel data, as well as a choice of analog, digital, and bar-graph meters. Waveform analysis can be performed, when applicable. A product support option, included on the data acquisition CD, provides a means of performing post data analysis. More information is included in the software-specific PDF documents that are installed on your hard-drive as a part of product support.

In addition to the included out-of-the-box software, Daq products can be controlled via user-written custom programs through Applications Program Interface (API). Several languages are supported, e.g., C/C++, VisualBASIC, Delphi.



DaqView and DASyLab can only be used with one DaqBoard/2000 Series board or /2000c Series board at a time. LabView can be used with multiple boards. For multiple board use (via custom programming) refer to the *Using Multiple Devices* section of the *Programmer's Manual*. During software installation from the data acquisition CD (p/n 1022-0601), a PDF version of the Programmer's Manual is automatically loaded onto your hard drive as a part of product support. The default location is the Programs directory.



Reference Note:

Programming topics are covered in the *Programmer's User Manual* (p/n 1008-0901). As a part of product support, this manual is automatically loaded onto your hard drive during software installation. The default location is the Programs directory, which can be accessed through the Windows Desktop.

DaqBooks, DaqBoards and Daq PC-Cards

Daq products connect to one or more DBKs on their signal input side and a computer on their output side. Each type of Daq device connects to the computer in a different way:

- The **DaqBook** is an external module that connects to a computer's enhanced parallel port (EPP) interface or PC-Card link.
- The **DaqBoard [ISA type]** board is an internal card that plugs into an ISA-bus slot within a computer.
- **DaqBoard/2000 Series Boards** plug into a PCI-bus slot, within a host PC.
- **DaqBoard/2000c Series** boards plug into a compact-PCI-bus slot, within a host PC.
- The **Daq PC-Card** slides into the PCMCIA slot of a host computer, typically a notebook PC.

Features common to the Daq products include:

- 100-kHz channel-to-channel scan *and* gain switching (10 μ s);
200-kHz for DaqBoard/2000 Series and DaqBoard/2000c Series Boards.
- 512-location sequence memory that can be loaded with any combination of channels and gains.
- Ability to access up to 256 different channels of DBK signals while maintaining the channel-to-channel scan rate. The DBK expansion options can accommodate mixed-signal inputs from thermocouples and RTDs to isolated high-voltage inputs and strain gages.
- Ability to handle 8 differential or 16 single-ended signal inputs without DBK expansion units.
- Ability to handle fixed digital I/O up to 4 TTL lines in and 4 TTL lines out (accessible only if no analog expansion cards are in use).

Daq Data Acquisition Devices		
Category	Device	Description
Primary Acquisition Device	DaqBook*	Portable Data Acquisition Modules 12-bit: DaqBook/100, /112, /120 16-bit: DaqBook/200, /216, /260
	DaqBoard/2000 Series	Plug-In Boards for PCI Bus-Slots 16-bit , 200 kHz. Six boards identified as /2000 through /2005
	DaqBoard/2000c Series	Plug-In Boards for Compact-PCI Bus-Slots 16-bit , 200 kHz. Six boards identified as /2000c through /2005c
	DaqBoard (ISA types)*	Plug-In Boards for ISA Bus-Slots 12-bit: DaqBoard/100A, /112A 16-bit: DaqBoard/200A, /216A, /2000
	Daq PC-Card*	Plug-In PCMCIA Card 12-bit: Daq/112B 16-bit: Daq/216B
DBK Option Cards and Modules	Analog Signal Conditioning	Cards and modules used to condition Analog Signals DBK/ 4, 7, 8, 9, 12, 13, 15, 17, 18, 19, 42, 43A, 44, 45, 50, 51, 52, 53, 54, 207, 207/CJC
	Analog Output	Cards used to modify Analog Output Signals DBK/ 2, 5
	Digital I/O and Control	Cards and modules used to condition Digital I/O DBK/ 20, 21, 23, 24, 25, 208
	Expansion Connections	Cards and modules used to expand the acquisition system. DBK/ 1, 10, 11A, 35, 40, 41, 60, 200, 201, 202, 203, 204, 205, 206, 209
	Power Supply	DBKs: 30A, 32A, 33, 34
Software	Included Software	DaqView, Post Data Acquisition Analysis Program (actual application not specified), Visual Basic extensions, Application Programming Interface (API)
	Optional Software	DaqView/2000, DaqViewXL, DASyLab

















Theory of Operation

for DaqBoard/2000 and /2000c Series Boards

As implied by the following matrix, the operational material does not apply globally to every DaqBoard/2000 Series board or /2000c Series board. For example, boards /2002, /2003, /2004, and their respective compact-PCI counterparts have no analog input.

For ease of understanding, each board is discussed independently, following the matrix. Note that pinouts are provided in chapter 2.

I/O Comparison Matrix

I/O Comparison Matrix for DaqBoard/2000 and /2000c Series Boards				
DaqBoard/ (PCI and compact-PCI versions)	Analog Input Channels Analog Input signals enter through P4 , go to MUX, to PGA, to Gain & Offset Amplifier, then to Analog- to-Digital Converter (ADC)	Analog Output Channels Digital Signals go through Digital-to-Analog Converters, then through “DAC Out” on P4.	Digital I/O Channels Digital signals pass through one 16-bit Digital I/O Port and three 8-bit Digital I/O Ports located on P4.	Counter/ Timers Four 16-bit Counter Input signals and Two 16-bit Timer Output signals via P4 and System Controller.
2000 and 2000c	 16	 2	 40	 6
2001 and 2001c	 16	 4	 40	 6
2002 and 2002c	--	--	 40	 6
2003 and 2003c	--	 4	--	--
2004 and 2004c	--	 4	 40	 6
2005 and 2005c	 16	--	 40	 6

Synchronous Input Operations

The DaqBoard/2000 Series and /2000c Series products allow synchronous scanning and acquisition of Analog Input, Digital Input and Counter Input Data at up to 200kHz aggregate scanning rates. The Analog Input data can be either main unit or expansion modules from P1 compatible analog input modules. The Digital Input data can be main unit 8-bit P2 (8255) digital inputs, 16-bit P3 digital inputs or P2 compatible DBK digital input expansion modules.

Analog Input Channels

The DaqBoard/2000 Series boards and /2000c Series boards that offer analog input (see matrix) allow analog input configuration for the board as well as the P1 compatible DBK analog input expansion modules.

Channel Selection and Mode Settings

The main unit accepts up to 16 single ended or up to 8 differential-ended inputs and can be programmed for single-ended or differential-ended on a per channel basis. Just one analog channel is sacrificed when a DBK expansion module is enabled. See DBK documentation in the *DBK Option Cards & Modules User's Manual* (p/n 457-0905) for further information.

Channel Range and Polarity

Each main unit channel also may be programmed for either unipolar or bipolar mode with gain settings of 1,2,4,8,16,32 and 64.

Channel Sampling Interval

The DaqBoard/2000 Series and /2000c Series boards allow programmable sampling intervals of 5us or 10us on a per channel basis. This mode allows some channels which change slowly but a higher degree of accuracy is desirable to be sampled at a longer interval while channels that change more rapidly to be sampled using a shorter interval. Each 5us or 10us interval reduces the maximum aggregate acquisition rate for the entire scan by that amount.

Digital Input Channels

The DaqBoard/2000 Series and /2000c Series boards allow either synchronous scanning of digital input channels or asynchronous I/O operations for all configured digital channels.

Counter Input Channels

The DaqBoard/2000 Series and /2000c Series boards allow synchronous scanning of the 4 16-bit counter input channels. The four 16-bit counter channels can also be cascaded into two 32-bit counter channels. For either cascaded or non-cascaded counter channels each channel can be configured for:

- **Pulse Counting Mode** – specifies that each counter should be cleared upon being read and placed into the input scan.
- **Totalize Counting Mode** – specifies that each counter is to free-run and not be cleared during the input acquisition.

Synchronous Input Acquisition Clocking

The DaqBoard/2000 Series and /2000c Series boards allow clocking of the synchronized inputs either by an internal, programmable pacer clock or by external clocking. These products use a sequencer to implement a multiplexing approach to gathering the input data. This means that with either internal or external clocking the entire channel scan (including the sampling time for each channel) may not exceed the maximum aggregate rate of 200kHz.

Synchronous Output Operations

The DaqBoard/2000 Series and /2000c Series boards allow synchronous output of any D/A or P3 16-bit Digital channels available at up to 100kHz for each channel. All D/A channels available and the 16-bit P3 Digital channel may have output streamed to them and clocked out synchronously. The D/A channels may be configured for waveform output and the P3 digital channel may be configured for streamed digital pattern output using the same clock sources.

Output Channel Configuration

Analog Output Channels

Each D/A channel can be configured for waveform output individually. If the D/A channel is not configured for waveform output it then is available for asynchronous output operations.

Digital Pattern Output Channel

The 16-bit P3 Digital Port can be configured for streamed digital pattern output. If not configured for streamed digital pattern output operations it then may be used for asynchronous digital I/O operations.

Synchronous Output Clocking

The DaqBoard/2000 Series and the /2000c Series boards allow clocking of the synchronized output by the acquisition clock source, an internal, programmable pacer clock or by an external clock source. When the clock source generates a new clock signal all outputs are updated concurrently. Regardless of the clock source, the clock may not exceed the maximum update rate of 100kHz.

Synchronous Output Data Source

The DaqBoard/2000 Series and /2000c Series boards allow the data source for synchronized output operations to be that of a memory based buffer or a file located on a mass storage medium. With either type of output data source, the output data for all the channels are contained in the buffer and/or file. The file path may be any file located on the on the machine or network accessible file.

Asynchronous I/O Operations

The DaqBoard/2000 Series and /2000c Series boards allow asynchronous input of any counter or digital channel that is not currently configured for synchronous acquisition. The boards also allow for asynchronous output to any D/A channels not currently configured for waveform output. Likewise, the 16-bit P3 digital port can be used for both asynchronous input and output operations if it is not currently configured for streamed pattern output operations. In addition, the timer outputs can be programmed at any time regardless of the current state of synchronous or asynchronous operations on other channels.

Digital I/O Channels

Local 8255 Channels

The DaqBoard/2000 Series and /2000c Series boards [which have digital I/O capabilities] have an implemented Intel 8255 core in the digital I/O logic on the P2 port of the product. With the Intel 8255 there are three 8-bit wide ports available for I/O and one 8-bit wide port for configuration purposes. The configuration port is used to configure the other three 8-bit ports for either input or output operations.

Local 16-bit P3 Port

The 16-bit P3 Digital Port can be used as either an input, or an output port. With this port, no configuration is required, the port simply outputs when written to and inputs when read.

Expansion Digital I/O

The DaqBoard/2000 Series and /2000c Series boards that have digital I/O capabilities have the ability to expand these through the P2 port and the connection of applicable digital I/O expansion modules. These modules are discussed in the *DBK Option Cards & Modules User's Manual*. When using the digital I/O expansion modules the local P2 Intel 8255 digital I/O becomes inaccessible in lieu of the expansion modules. These expansion modules provide additionally Intel 8255 ports as well as input isolation for applications that require the expanded capabilities.

Pulse Stream Output Using Timers

The boards allow the generation of output pulses based upon a programmable setting. These output timers can be set at any time regardless of the state of any synchronous or asynchronous operations which are currently taking place on other channels.

Analog Output Channels

The boards that have analog output capabilities have the ability to output analog data to any of the available (up to four) D/A channels. Each D/A channel may be asynchronously updated by an application if the D/A channel is not currently being used for waveform output operations.

Counter Input Channels

With exception of DaqBoard/2003 and /2003c, the boards have counter input capabilities and have the ability to read counter input [if the counter channel is not configured for synchronous acquisition]. As in the case of synchronous operations the 4 16-bit counter input channels can be used individually or cascaded into 2 32-bit counter channels. For either cascaded or non-cascaded counter channels each channel can be configured for:

- **Clear on Read Mode** - specifies that each counter should be cleared (reset to 0) upon being read.
- **Continuous Totalize Mode** – specifies that each counter is to *free-run* and not be cleared during the read operation.

Operation Matrix*

This chart refers to both the DaqBoard/2000 Series and the DaqBoard/2000c Series Boards.

Operation	2000 and 2000c	2001 and 2001c	2002 and 2002c	2003 and 2003c	2004 and 2004c	2005 and 2005c
Synchronous Input						
Analog Main Unit Inputs (P1)	Yes	Yes	No	No	No	Yes
Analog Expansion Input (P1)	Yes	Yes	No	No	No	Yes
Counter Inputs (P3)	Yes	Yes	Yes	No	Yes	Yes
Digital Main Unit Inputs (P2)	Yes	Yes	Yes	No	Yes	Yes
Digital Expansion Inputs (P2)	Yes	Yes	Yes	No	Yes	Yes
Digital Inputs (P3)	Yes	Yes	Yes	No	Yes	Yes
Synchronous Output						
Analog D/A Waveform Output	Yes(2)	Yes(4)	No (0)	Yes(4)	Yes(4)	No (0)
Streamed Digital Output (16-bit P3)	Yes	Yes	Yes	No	Yes	Yes
Asynchronous IO						
Main Unit Digital I/O	Yes	Yes	Yes	No	Yes	Yes
Expansion Digital I/O	Yes	Yes	Yes	No	Yes	Yes
Timer Output (Pulse Generation)	Yes	Yes	Yes	No	Yes	Yes
Analog Output	Yes(2)	Yes(4)	No (0)	Yes(4)	Yes(4)	No (0)

* A similar matrix, intended to highlight board differences at a glance, is presented on page 1-4.



DaqBoard/2000 & DaqBoard/2000c

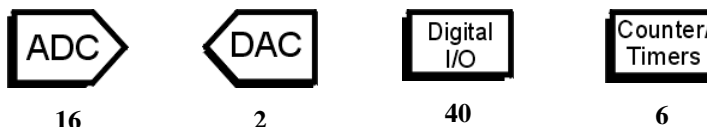

DaqBoard/2000 and DaqBoard/2000c are high-speed, multi-function, plug-and-play data acquisition boards for PCI and compact-PCI bus computers, respectively. They feature a 16-bit, 200-kHz A/D converter, digital calibration, bus mastering DMA, two 16-bit, 100-kHz D/A converters, 40 digital I/O lines, four counters, and two timers.

Up to 470 channels of analog and digital I/O can be accessed with one DaqBoard/2000 or DaqBoard/2000c. Up to four boards can be installed into a PC.

A 100-pin connector on the boards provides access to all of the input and output signals. The DaqBoard/2000 and /2000c accommodate all I/O with one cable and one PCI [or compact-PCI] slot. The 100-pin I/O connector, P4, is logically divided into three ports:

- **P1** – Analog input port for 16 single-ended or 8 differential analog inputs with 13 software programmable ranges (± 10 V to ± 156 mV full scale).
- **P2** – General purpose digital I/O port with 24 lines, or digital I/O expansion port controlling up to 192 external lines.
- **P3** – 16-bit digital I/O port, counter inputs, timer outputs, and analog outputs.

The on-board scan sequencer lets you select up to 512 channel/range combinations. The sequencer scans all channels of the scan at 5 μ s or 10 μ s/channel.

Bus mastering allows analog and digital/counter input data, as well as analog and digital output data, to flow between the PC and the DaqBoard/2000 or /2000c without consuming CPU time.

DaqBoard/2000 and DaqBoard/2000c support a full complement of trigger modes including:

- **Hardware analog triggering** – A user-programmed trigger level sets an analog DAC, which is compared in hardware to the analog input level on the selected channel. Trigger latency is < 5 μ s.
- **Digital and pattern triggering** – The boards have separate digital trigger input line, allowing TTL-level triggering and latencies less than 5 μ s. The trigger can be programmed for logic level or edge triggering. In pattern triggering, any of the digital input ports acts as the trigger port. You can program the digital pattern.
- **Software-based triggering** – The PC detects the trigger event from readings, either analog, digital, or counter. Six pre- and post-triggering modes are supported.

The two 16-bit, 100-kHz analog output channels have an output from -10 V to $+10$ V. (These channels are separate from the D/As used to determine analog trigger levels.) Using Bus Mastering DMA, each D/A can output a waveform. Bus Mastering DMA also allows for digital pattern generation on the 16-bit high-speed digital I/O port.

Other features of the DaqBoard/2000 and the DaqBoard/2000c include:

- **40 TTL-level digital I/O lines.** They are divided into three 8-bit ports and one 16-bit port.
- **Four 16-bit counters.** Each can accept frequency inputs up to 10 MHz. The counters can be cascaded into two 32-bit counters.
- **Two 16-bit timer outputs.** Each can generate square waves from 16 Hz to 1 MHz.
- **Configuration through software.** There are no switches or jumpers on the DaqBoard/2000 or on the DaqBoard/2000c.

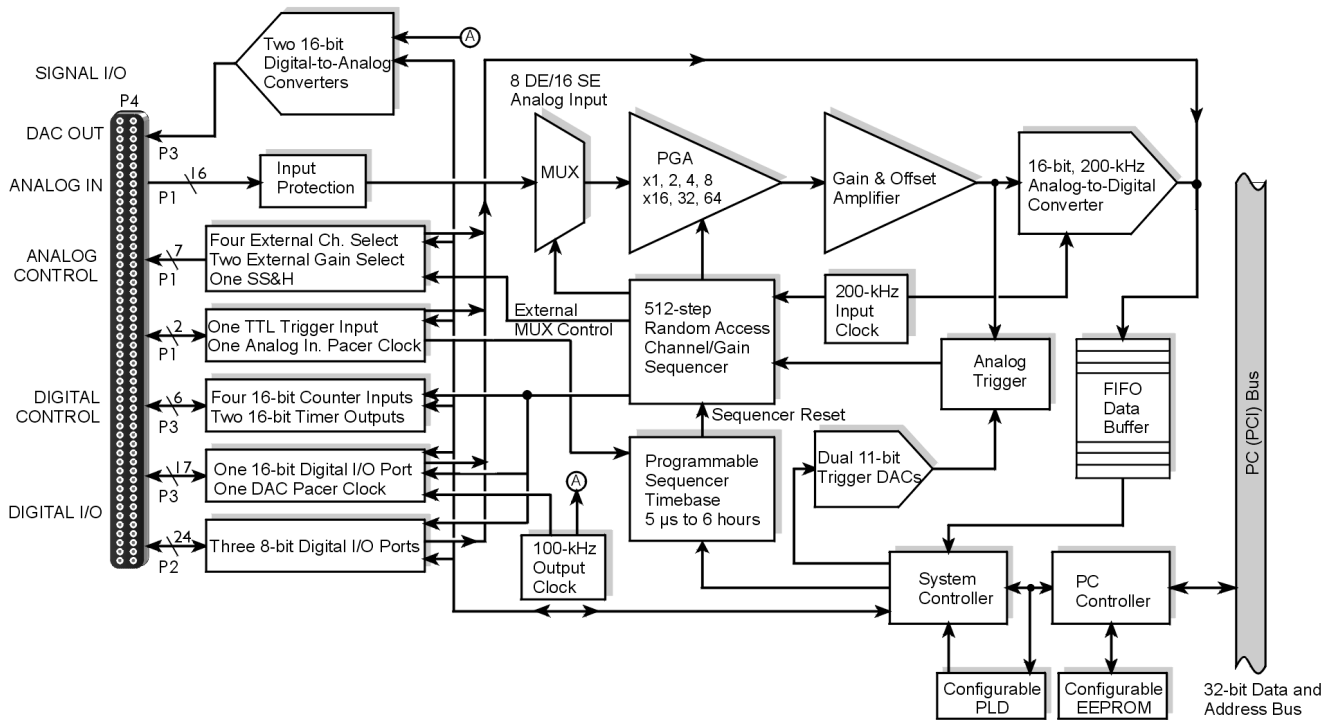

DaqBoard/2000 Block Diagram*

* The DaqBoard/2000c Block Diagram is the same, with exception that the /2000c board uses a compact-PCI Bus instead of a standard PCI bus.

Connections

Installation



Reference Note: For the DaqBoard/2000 and DaqBoard/2000c installation procedure, refer to either the [DaqBoard/2000 Series Installation Guide](#) or to the [DaqBoard/2000c Series Installation Guide](#), as applicable. The guides are included at the beginning of this manual.

I/O Connectors

All input and output signals are available at the board's 100-pin P4 connector. A 3-foot, 100-conductor ribbon cable, part number CA-195, mates with connector P4.



Reference Note: There are several P4-connector board options available for connecting the 100 pins of P4 to typical DB37 connectors (P1, P2, and P3). In addition to being briefly discussed in chapter 2 of this manual, these options, referred to as [DBK200 Series](#), are detailed in the [DBK Cards and Modules User's Manual](#) (p/n 457-0905).

DaqBoard/2001 & DaqBoard/2001c

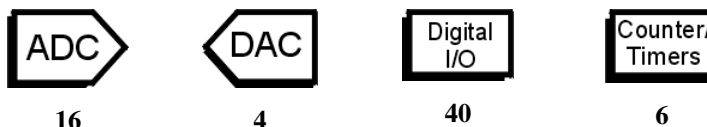

DaqBoard/2001 and DaqBoard/2001c are high-speed, multi-function, plug-and-play data acquisition boards for PCI or compact-PCI bus computers, respectively. They feature a 16-bit, 200-kHz A/D converter, digital calibration, bus mastering DMA, four 16-bit, 100-kHz D/A converters, 40 digital I/O lines, four counters, and two timers.

Up to 470 channels of analog and digital I/O can be accessed with one DaqBoard/2001 or one /2001c board. Up to four boards can be installed into a PC.

A 100-pin connector on the DaqBoard/2001 or /2001c provides access to all of the input and output signals. The boards accommodate all I/O with one cable and one PCI [or compact-PCI] slot. The 100-pin I/O connector, P4, is logically divided into three ports:

- **P1** – Analog input port for 16 single-ended or 8 differential analog inputs with 13 software programmable ranges (± 10 V to ± 156 mV full scale).
- **P2** – General purpose digital I/O port with 24 lines, or digital I/O expansion port controlling up to 192 external lines.
- **P3** – 16-bit digital I/O port, counter inputs, timer outputs, and analog outputs.

The on-board scan sequencer lets you select up to 512 channel/range combinations. The sequencer scans all channels of the scan at 5 μ s or 10 μ s/channel.

Bus mastering allows analog and digital/counter input data, as well as analog and digital output data, to flow between the PC and the DaqBoard/2001, or to the DaqBoard/2001c, without consuming CPU time.

DaqBoard/2001 and DaqBoard/2001c support a full complement of trigger modes including:

- **Hardware analog triggering** – A user-programmed trigger level sets an analog DAC, which is compared in hardware to the analog input level on the selected channel. Trigger latency is < 5 μ s.
- **Digital and pattern triggering** – The DaqBoard/2001 and /2001c have separate digital trigger input line, allowing TTL-level triggering and latencies less than 5 μ s. The trigger can be programmed for logic level or edge triggering. In pattern triggering, any of the digital input ports acts as the trigger port. You can program the digital pattern.
- **Software-based triggering** – The PC detects the trigger event from readings, either analog, digital, or counter. Six pre- and post-triggering modes are supported.

The four 16-bit, 100-kHz analog output channels have an output from -10 V to $+10$ V. (These channels are separate from the D/As used to determine analog trigger levels.) Using Bus Mastering DMA, each D/A can output a waveform. Bus Mastering DMA also allows for digital pattern generation on the 16-bit high-speed digital I/O port.

Other features of the DaqBoard/2001 and /2001c include:

- **40 TTL-level digital I/O lines.** They are divided into three 8-bit ports and one 16-bit port.
- **Four 16-bit counters.** Each can accept frequency inputs up to 10 MHz. The counters can be cascaded into two 32-bit counters.
- **Two 16-bit timer outputs.** Each can generate square waves from 16 Hz to 1 MHz.
- **Configuration through software.** There are no switches or jumpers on the DaqBoard/2001 or on the DaqBoard/2001c.

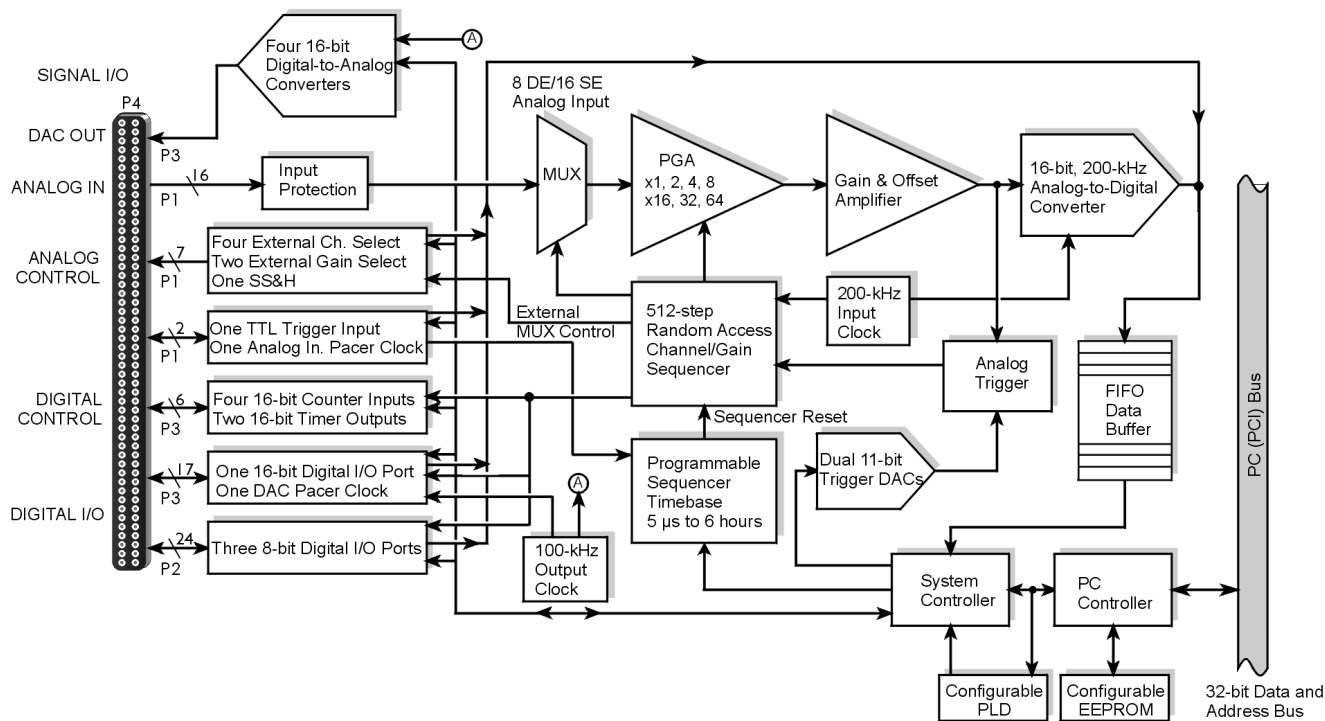

DaqBoard/2001 Block Diagram*

* The DaqBoard/2001c Block Diagram is the same, with exception that the /2001c board uses a compact-PCI Bus instead of a standard PCI bus.

Connections

Installation



Reference Note: For the DaqBoard/2001 and /2001c installation procedure, refer to either the [DaqBoard/2000 Series Installation Guide](#) or to the [DaqBoard/2000c Series Installation Guide](#), as applicable. The guides are included at the beginning of this manual.

I/O Connector

All input and output signals are available at the board's 100-pin P4 connector. A 3-foot, 100-conductor ribbon cable, part number CA-195, mates with connector P4.



Reference Note: There are several P4-connector board options available for connecting the 100 pins of P4 to typical DB37 connectors (P1, P2, and P3). In addition to being briefly discussed in chapter 2 of this manual, these options, referred to as **DBK200 Series**, are detailed in the [DBK Cards and Modules User's Manual](#) (p/n 457-0905).

DaqBoard/2002 & DaqBoard/2002c

Digital I/O	Counter/ Timers
40	6

DaqBoard/2002 and /2002c are high-speed, multi-function, plug-and-play data acquisition boards for PCI and compact-PCI bus computers, respectively. They feature digital calibration, bus mastering DMA, 40 digital I/O lines, four counters, and two timers.

Up to 470 channels of analog and digital I/O can be accessed with one board. Up to four boards can be installed into a PC.

A 100-pin connector on the boards provides access to all of the input and output signals. The boards accommodate all I/O with one cable and one PCI [or compact-PCI] slot. The 100-pin I/O connector, P4, is logically divided into three ports:

- **P1** – Not used by DaqBoard/2002 or DaqBoard/2002c
- **P2** – General purpose digital I/O port with 24 lines, or digital I/O expansion port controlling up to 192 external lines.
- **P3** – 16-bit digital I/O port, counter inputs, timer outputs, and analog outputs.

The on-board scan sequencer lets you select up to 512 channel/range combinations. The sequencer scans all channels of the scan at 5 μ s or 10 μ s/channel.

Bus mastering allows digital/counter input data and digital output data to flow between the PC and the DaqBoard/2002 or /2002c board without consuming CPU time.

DaqBoard/2002 and DaqBoard/2002c each supports a complement of trigger modes including:

- **Digital and pattern triggering** – The boards have separate digital trigger input line, allowing TTL-level triggering and latencies less than 5 μ s. The trigger can be programmed for logic level or edge triggering. In pattern triggering, any of the digital input ports acts as the trigger port. You can program the digital pattern.
- **Software-based triggering** – The PC detects the trigger event from readings [digital, or counter]. Six pre- and post-triggering modes are supported.

Other features of the DaqBoard/2002 and DaqBoard/2002c include:

- **40 TTL-level digital I/O lines.** They are divided into three 8-bit ports and one 16-bit port.
- **Four 16-bit counters.** Each can accept frequency inputs up to 10 MHz. The counters can be cascaded into two 32-bit counters.
- **Two 16-bit timer outputs.** Each can generate square waves from 16 Hz to 1 MHz.
- **Configuration through software.** There are no switches or jumpers on the DaqBoard/2002 or the DaqBoard/2002c.

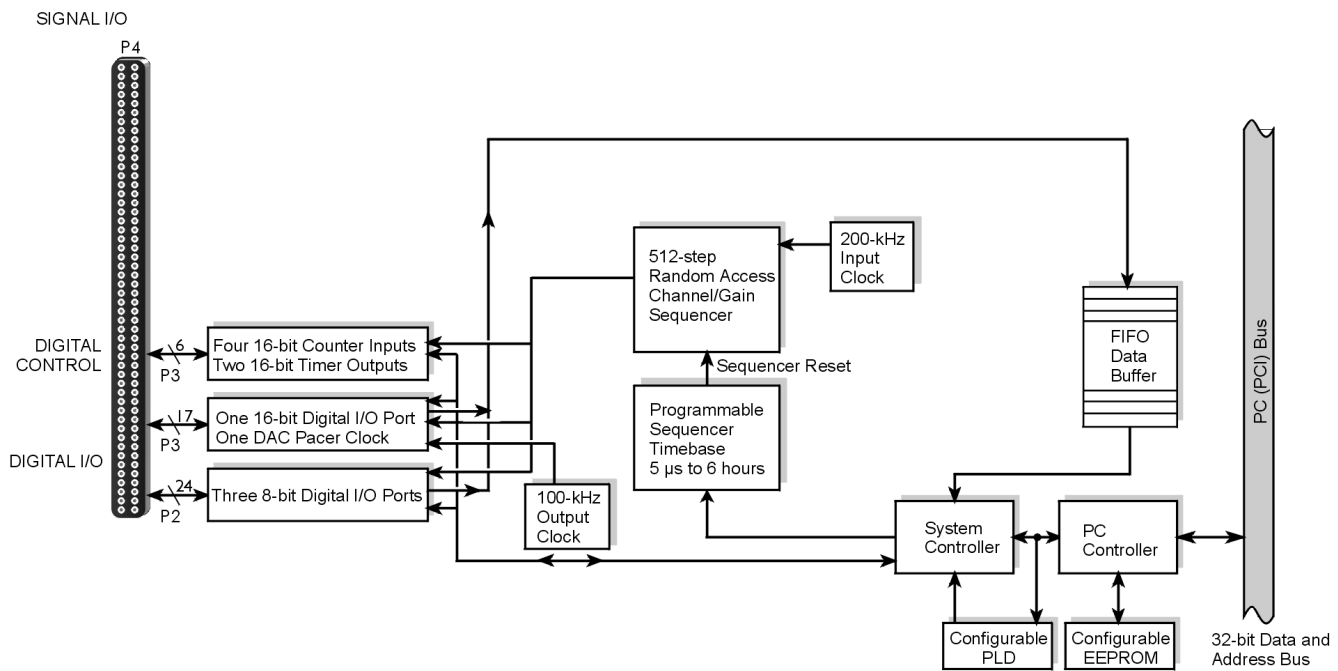

DaqBoard/2002 Block Diagram*

*The DaqBoard/2002c Block Diagram is the same, with exception that the /2002c board uses a compact-PCI Bus instead of a standard PCI bus.

Connections

Installation



Reference Note: For the DaqBoard/2002 and compact-PCI DaqBoard/2002c installation procedure, refer to either the [DaqBoard/2000 Series Installation Guide](#) or to the [DaqBoard/2000c Series Installation Guide](#), as applicable. The guides are included at the beginning of this manual.

I/O Connector

All input and output signals are available at the board's 100-pin P4 connector. A 3-foot, 100-conductor ribbon cable, part number CA-195, mates with connector P4.



Reference Note: There are several P4-connector board options available for connecting the 100 pins of P4 to typical DB37 connectors (P1, P2, and P3). In addition to being briefly discussed in chapter 2 of this manual, these options, referred to as [DBK200 Series](#), are detailed in the [DBK Cards and Modules User's Manual](#) (p/n 457-0905).

DaqBoard/2003 & DaqBoard/2003c



4

DaqBoard/2003 and /2003c are high-speed plug-and-play data acquisition boards for PCI and compact-PCI bus computers, respectively. The boards are used for analog output and include four 16-bit, 100-kHz D/A converters. Up to four boards can be installed into a PC.

A 100-pin connector on the boards provides access to the DAC analog output signals. The boards plug directly into a PCI or compact-PCI bus slot, as applicable. The DAC analog output leaves the board through “P3-designated” pins located on the board’s 100-pin P4 connector.

Both boards support **Software-based triggering**. In “Software-based” triggering the PC detects the trigger event from the readings. Six pre- and post-triggering modes are supported.

DBK205

Terminations

TB1-1	AGND
TB1-2	DAC0
TB1-3	AGND
TB1-4	DAC1
TB1-5	AGND
TB1-6	DAC2
TB1-7	AGND
TB1-8	DAC3
TB1-9	AGND
TB1-10	XTTL
TB1-11	CLK
TB1-12	DGND

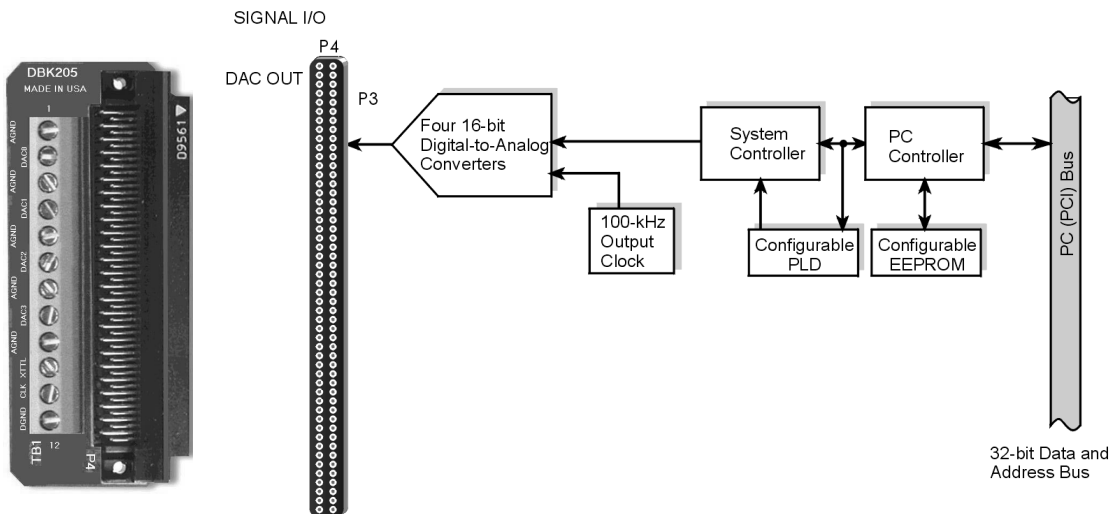

DBK205 Adapter

DaqBoard/2003 Block Diagram

Note: DaqBoard/2003 and DaqBoard/2003c are shipped with one DBK205 adapter. The adapter has twelve screw terminals as follows: DAC0, DAC1, DAC2, DAC3, 1 digital ground, 5 analog grounds, 1 external clock (CLK), and 1 external trigger (XTTL). DBK205 connects directly to DaqBoard/2003’s P4 connector.

Connections

Installation



Reference Note: For the DaqBoard/2003 and DaqBoard/2003c installation procedure, refer to either the [DaqBoard/2000 Series Installation Guide](#) or to the [DaqBoard/2000c Series Installation Guide](#), as applicable. The guides are included at the beginning of this manual.

I/O Connector

Analog output signals are available at the board’s 100-pin P4 connector. A 3-foot, 100-conductor ribbon cable, part number CA-195, mates with connector P4; however, a DBK205 adapter board is included for connecting the 100 pins of P4 to a terminal block (TB1).

DBK205’s TB1 includes screw terminals for: DAC0, DAC1, DAC2, and DAC3, 1 digital ground, 5 analog grounds, 1 external clock (CLK), and 1 external trigger (XTTL). DBK205 connects directly to DaqBoard/2003’s P4 connector or compact-PCI DaqBoard/2003c’s P4 connector.

DBK205 is depicted as part of the block diagram above and is discussed briefly in chapter 2 of this manual. DBK205 is also discussed in the [DBK Cards and Modules User’s Manual](#) (p/n 457-0905).



DaqBoard/2004 & DaqBoard/2004c



DaqBoard/2004 and /2004c are high-speed, multi-function, plug-and-play data acquisition boards for PCI and compact-PCI bus computers, respectively. They feature bus mastering DMA, four 16-bit, 100-kHz D/A converters, 40 digital I/O lines, four counters, and two timers.

Up to four boards can be installed in one PC.

A 100-pin connector on the boards provides access to all of the input and output signals. Each board accommodates all I/O with one cable and one PCI [or compact-PCI] slot, as applicable. The 100-pin I/O connector, P4, is logically divided into three ports: P1, P2, and P3; however, DaqBoard/2004 and /2004c only make use of the P2 and P3 pin designations.

- **P1** – Not used by DaqBoard/2004 or by DaqBoard/2004c
- **P2** – General purpose digital I/O port with 24 lines, or digital I/O expansion port controlling up to 192 external lines.
- **P3** – 16-bit digital I/O port, counter inputs, timer outputs, and analog outputs.

The on-board scan sequencer lets you select up to 512 channel/range combinations. The sequencer scans all channels of the scan at 5 μ s or 10 μ s per channel.

Bus mastering allows the digital/counter input data and analog and digital output data to flow between the PC and the DaqBoard/2004 [or DaqBoard/2004c] without consuming CPU time.

DaqBoard/2004 and DaqBoard/2004c support several trigger modes, including:

- **Digital and pattern triggering** – Each board has a separate digital trigger input line, allowing TTL-level triggering and latencies less than 5 μ s. The trigger can be programmed for logic level or edge triggering. In pattern triggering, any of the digital input ports acts as the trigger port. You can program the digital pattern.
- **Software-based triggering** – The PC detects the trigger event from readings, either analog, digital, or counter. Six pre- and post-triggering modes are supported.

The four 16-bit, 100-kHz analog output channels have an output from -10 V to $+10$ V. Using Bus Mastering DMA, each D/A can output a waveform. Bus Mastering DMA also allows for digital pattern generation on the 16-bit high-speed digital I/O port.

Other features of the DaqBoard/2004 and DaqBoard/2004c include:

- **40 TTL-level digital I/O lines.** They are divided into three 8-bit ports and one 16-bit port.
- **Four 16-bit counters.** Each can accept frequency inputs up to 10 MHz. The counters can be cascaded into two 32-bit counters.
- **Two 16-bit timer outputs.** Each can generate square waves from 16 Hz to 1 MHz.
- **Configuration through software.** There are no switches or jumpers on the DaqBoard/2004 or on the /2004c.

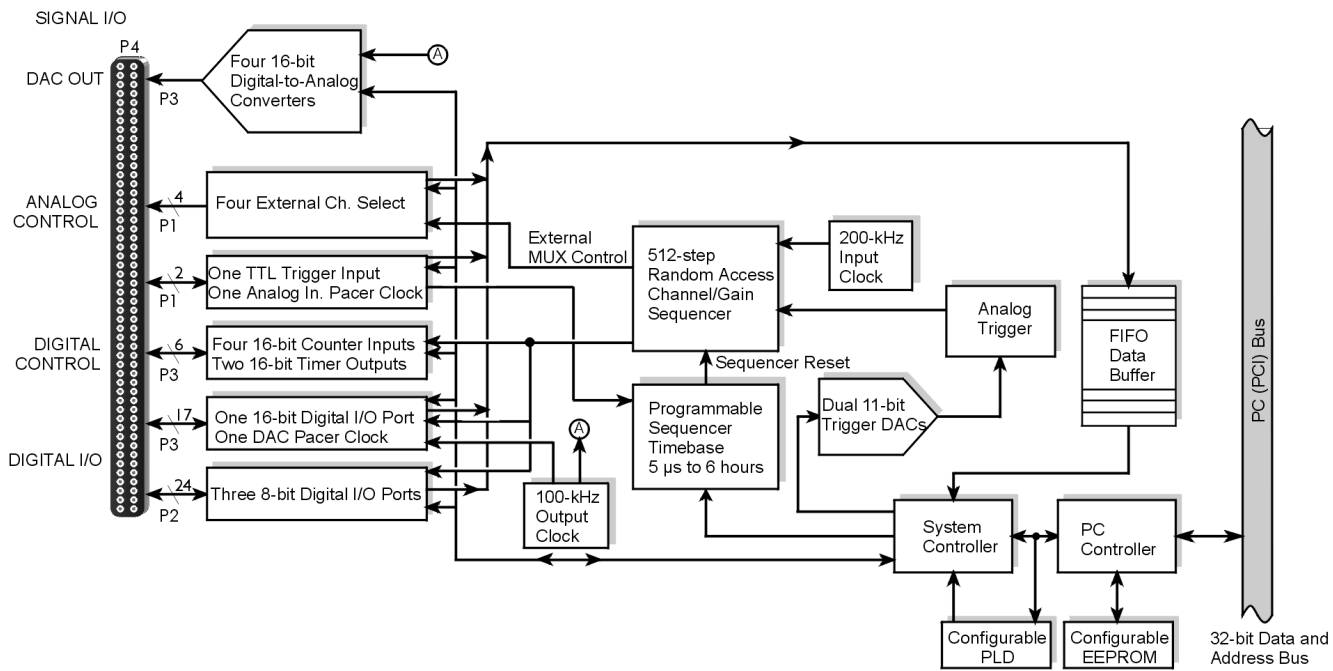

DaqBoard/2004 Block Diagram*

* The DaqBoard/2004c Block Diagram is the same, with exception that the /2004c board uses a compact-PCI Bus instead of a standard PCI bus.

Connections

Installation



Reference Note: For the DaqBoard/2004 and DaqBoard/2004c installation procedure, refer to either the [DaqBoard/2000 Series Installation Guide](#) or to the [DaqBoard/2000c Series Installation Guide](#), as applicable. The guides are included at the beginning of this manual.

I/O Connector

All input and output signals are available at the board's 100-pin P4 connector. A 3-foot, 100-conductor ribbon cable, part number CA-195, mates with connector P4.



Reference Note: There are several P4-connector board options available for connecting the 100 pins of P4 to typical DB37 connectors (P1, P2, and P3). In addition to being briefly discussed in chapter 2 of this manual, these options, referred to as [DBK200 Series](#), are detailed in the [DBK Cards and Modules User's Manual](#) (p/n 457-0905).

DaqBoard/2005 & DaqBoard/2005c

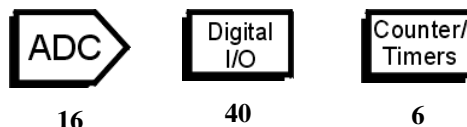

DaqBoard/2005 and DaqBoard/2005c are high-speed, multi-function, plug-and-play data acquisition boards for PCI and compact-PCI bus computers, respectively. They feature a 16-bit, 200-kHz A/D converter, digital calibration, bus mastering DMA, 40 digital I/O lines, four counters, and two timers.

Up to 470 channels of analog and digital I/O can be accessed with one board. Up to four boards can be installed in one PC.

A 100-pin connector on the board provides access to all of the input and output signals. The Each board accommodates all I/O with one cable and one PCI [or compact-PCI] bus-slot, as applicable. The 100-pin I/O connector, P4, is logically divided into three ports:

- **P1** – Analog input port for 16 single-ended or 8 differential analog inputs with 13 software programmable ranges (± 10 V to ± 156 mV full scale).
- **P2** – General purpose digital I/O port with 24 lines, or digital I/O expansion port controlling up to 192 external lines.
- **P3** – 16-bit digital I/O port, counter inputs, and timer outputs.

The on-board scan sequencer lets you select up to 512 channel/range combinations. The sequencer scans all channels of the scan at 5 μ s or 10 μ s per channel.

Bus mastering allows analog and digital/counter input data, as well as analog and digital output data, to flow between the PC and the board without consuming CPU time.

DaqBoard/2005 and DaqBoard/2005c support a full complement of trigger modes, including:

- **Hardware analog triggering** – A user-programmed trigger level sets an analog DAC, which is compared in hardware to the analog input level on the selected channel. Trigger latency is < 5 μ s.
- **Digital and pattern triggering** – Both boards have a separate digital trigger input line, allowing TTL-level triggering and latencies less than 5 μ s. The trigger can be programmed for logic level or edge triggering. In pattern triggering, any of the digital input ports acts as the trigger port. You can program the digital pattern.
- **Software-based triggering** – The PC detects the trigger event from readings, either analog, digital, or counter. Six pre- and post-triggering modes are supported.

Bus Mastering DMA also allows for digital pattern generation on the 16-bit high-speed digital I/O port.

Other features of the DaqBoard/2005 and DaqBoard/2005c include:

- **40 TTL-level digital I/O lines.** They are divided into three 8-bit ports and one 16-bit port.
- **Four 16-bit counters.** Each can accept frequency inputs up to 10 MHz. The counters can be cascaded into two 32-bit counters.
- **Two 16-bit timer outputs.** Each can generate square waves from 16 Hz to 1 MHz.
- **Configuration through software.** There are no switches or jumpers on the DaqBoard/2005 or DaqBoard/2005c.

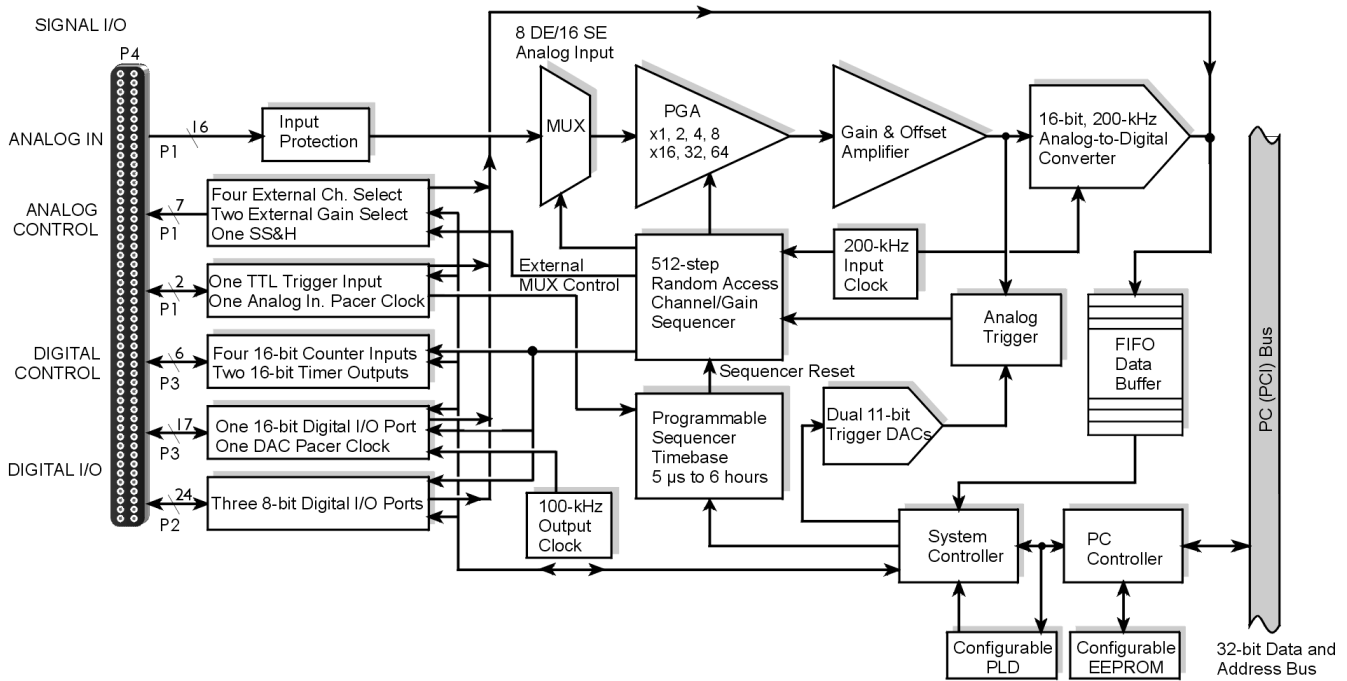

DaqBoard/2005 Block Diagram*

*The DaqBoard/2005c Block Diagram is the same, with exception that the /2005c board uses a compact-PCI Bus instead of a standard PCI bus.

Connections

Installation



Reference Note: For the DaqBoard/2005 and compact-PCI DaqBoard/2005c installation procedure, refer to either the [DaqBoard/2000 Series Installation Guide](#) or to the [DaqBoard/2000c Series Installation Guide](#), as applicable. The guides are included at the beginning of this manual.

I/O Connector

All input and output signals are available at the board's 100-pin P4 connector. A 3-foot, 100-conductor ribbon cable, part number CA-195, mates with connector P4.



Reference Note: There are several P4-connector board options available for connecting the 100 pins of P4 to typical DB37 connectors (P1, P2, and P3). In addition to being briefly discussed in chapter 2 of this manual, these options, referred to as [DBK200 Series](#), are detailed in the [DBK Cards and Modules User's Manual](#) (p/n 457-0905).

Using DBK Cards and Modules for Signal Conditioning

The DBK signal-conditioning cards and module are designed for use with DaqBooks, LogBooks, and various types of data acquisition boards, i.e., ISA, PCI, and compact-PCI types. The DBKs perform best when used with an acquisition device that can dynamically select channel, gain, and range. DBK cards and modules with dynamic channel and gain/range selection allow for high channel-to-channel scan rates with a variety of transducers.

Note: Only *passive* DBKs, such as the DBK1 BNC module, the DBK11A screw terminal card, and the DBK40 BNC analog interface, can be used with Daq PC-Cards.

DBK output signals can be bipolar, e.g., -5 to +5 V, or unipolar, e.g., 0 to 10 V. The user can select a range of relevant values to correspond to the lowest signal (e.g., -5 or 0 V) and the highest signal (e.g., 5 or 10 V) signal. This type of range selection guarantees the highest resolution in 12-bit or 16-bit conversion.

DBK modules share the same footprint as the DaqBook and a typical notebook PCs; allowing for convenient stacking. The majority of these modules have their own power supply; however, several options exist for packaging and powering the DBKs.



Reference Note:

DBK options are detailed in the [DBK Option Cards and Modules User's Manual](#) (p/n 457-0905). As a part of product support, this manual is automatically loaded onto your hard drive during software installation. The default location is the Programs directory, which can be accessed through the Windows Desktop.

Daq Software

The Daq devices have software options capable of handling most applications. Three types of software are available:

- ready-to-use graphical programs, e.g., DaqView, DaqViewXL, and post acquisition data analysis programs such as PostView, DIAdem, and eZ-View
- drivers for third-party, icon-driven software such as DASyLab and LabView
- various language drivers to aid custom programming using API

Ready-to-use programs are convenient for fill-in-the-blank applications that do not require programming for basic data acquisition and display:

- DaqView is a Windows-based program for basic set-up and data acquisition. DaqView lets you select desired channels, gains, transducer types (including thermocouples), and a host of other parameters with a click of a PC's mouse. DaqView lets you stream data to disk and display data in numerical or graphical formats. PostView is a post-acquisition waveform-display program within DaqView.
- DaqViewXL allows you to interface directly with Microsoft Excel to enhance data handling and display. Within Excel you have a full-featured Daq control panel and all the data display capabilities of Excel.
- Post acquisition data analysis programs, e.g., PostView, DIAdem, and eZ-View, typically allow you to view and edit post-acquisition data.
- The Daq Configuration control panel allows for interface configuration, testing, and troubleshooting.

Each Daq system comes with an Application Programming Interface (API). API-language drivers include: C/C++, Delphi, and Visual Basic. The latest software is a 32-bit version API.



Reference Notes:

- The software document modules, *DaqView*, *DaqViewXL*, and *Post Acquisition Data Analysis User's Guide*, are not included as part of the hardcopy manual, but are available in PDF version. See the PDF Note, below.
- Programming topics are covered in the *Programmer's User Manual* (1008-0901). As a part of product support, this manual is automatically loaded onto your hard drive during software installation. The default location is the Programs directory, which can be accessed through the Windows Desktop.

PDF Note: During software installation, Adobe® PDF versions of user manuals will automatically install onto your hard drive as a part of product support. The default location is in the **Programs** directory, which can be accessed from the *Windows Desktop*. Refer to the PDF documentation for details regarding both hardware and software.

















A copy of the Adobe Acrobat Reader® is included on your CD. The Reader provides a means of reading and printing the PDF documents. Note that hardcopy versions of the manuals can be ordered from the factory.

Specifications

Note: Specifications are subject to change without notice.

DaqBoard/2000 Series and DaqBoard/2000c Series Boards

DaqBoard/2000 Series and DaqBoard/2000c I/O Comparison Matrix

DaqBoard/ (2000 Series)	Analog Input Channels	Analog Output Channels	Digital I/O Channels	Counter/ Timers
	Analog Input signals enter through P4 , go to MUX, to PGA, to Gain & Offset Amplifier, then to Analog-to-Digital Converter (ADC)	Digital Signals go through Digital-to-Analog Converters, then through "DAC Out" on P4.	Digital signals pass through one 16-bit Digital I/O Port and three 8-bit Digital I/O Ports located on P4.	Four 16-bit Counter Input signals and Two 16-bit Timer Output signals via P4 and System Controller.
2000 and 2000c	16 	2 	40 	6 
2001 and 2001c	16 	4 	40 	6 
2002 and 2002c	--	--	40 	6 
2003 and 2003c	--	4 	--	--
2004 and 2004c	--	4 	40 	6 
2005 and 2005c	16 	--	40 	6 

General Specifications

Applicable to all DaqBoard/2000 Series and DaqBoard/2000c Series Boards

Warm-up: 1 hour to rated specifications

Supply voltage range: 4.75 VDC to 5.25 VDC (PCI bus)

Power consumption (per board): 3.5 W (up to 10 W with external accessories)

Power Available for External Signal Conditioning and Expansion Options:

5 V at 1 A (all boards); ± 15 V at 75 mA each (with exception of DaqBoard/2002)

Operating temperature: 0 to +60°C

Storage temperature: -40 to +80°C

Relative Humidity: 0 to 95% non-condensing

Vibration: MIL Std 810E

Dimensions:

DaqBoard/2000 Series: 165 mm W x 15 mm D x 108 mm H (6.5" x 0.6" x 4.2")

DaqBoard/2000c Series: 160mm W x 19 mm D x 100 mm H (6.3" x 0.7" x 3.9")

Weight:

DaqBoard/2000 Series: 160 g (0.35 lbs)

DaqBoard/2000c Series: 178.95 g (0.39 lbs)

Analog Specifications

Applicable to DaqBoard/2000, /2001, /2005, /2000c, /2001c, and /2005c

A/D: Successive approximation, 200 kHz maximum conversion rate

Resolution: 16 bits

Channels: 16 single-ended or 8 differential, expandable up to 256 differential

Conversion Time: 5 μ s

Connector: 100-pin high-density edge-type

Missing Codes: None, over full operating temperature range

Input Voltage Ranges (software programmable via sequencer):				
Voltage Range	Accuracy (Note 2) One Year, 0 to 35°C \pm (% reading+% range)		Input Noise (LSB rms) 10 Hz-200 kHz (Note 4)	Notes
	Absolute	Transfer (Note 3)		
0 to +10 V	0.015+.005	0.004+.002	1	(1) Specifications assume differential input single channel scan, 200 kHz scan rate, unfiltered. (2) Accuracy specification is exclusive of noise. (3) Transfer accuracy assumes calibration inside computer; applicable for measurements made $\pm 5^\circ$ C from ambient temperature at calibration (4) Inputs shorted to P4-45A, differential input, 8192 samples.
0 to +5 V	0.015+.005	0.004+.002	1	
0 to +2.5 V	0.015+.005	0.004+.002	1	
0 to +1.25 V	0.015+.008	0.004+.002	2	
0 to +0.625 V	0.015+.008	0.004+.002	2	
0 to +0.3125 V	0.015+.008	0.004+.003	2	
-10 to +10 V	0.015+.005	0.004+.001	1	
-5 to +5 V	0.015+.005	0.004+.001	1	
-2.5 to +2.5 V	0.015+.005	0.004+.001	1	
-1.25 to +1.25 V	0.015+.005	0.004+.001	2	
-0.625 to +0.625 V	0.015+.008	0.004+.001	2	
-0.3125 to +0.3125 V	0.015+.008	0.004+.0015	3	
-0.156 to +0.156 V	0.02+.008	0.004+.0015	3	

Voltage Specifications (one year, 0-35°C)

Applicable to DaqBoard/2000, /2001, /2005, /2000c, /2001c, and /2005c

Differential Nonlinearity: ± 2 LSB maximum

Integral Nonlinearity: ± 1 LSB maximum

Temperature Coefficient: $\pm(10 \text{ ppm} + 0.3 \text{ LSB})/^{\circ}\text{C}$ typical

Input Impedance: 10 M Ω (single ended); 20 M Ω (differential), in parallel with 50 pF

Bias Current: <1 nA (0 to 35°C)

Common Mode Rejection: 86 dB typical, from DC to 60 Hz for gains ≤ 8 ; 95 dB typical, from DC to 60 Hz for gains ≥ 16

Hostile Channel-to-channel Crosstalk: 100 dB DC to 60 Hz; 86 dB @ 10 kHz

Maximum Input Voltage: ± 11 V relative to analog common

Over-Voltage Protection: ± 35 V relative to analog common

Input Sequencer

Applicable to DaqBoard/2000, /2001, /2002, /2004, /2005, /2000c, /2001c, /2004c, and /2005c

Analog, digital and counter inputs can be scanned synchronously based either on an internal programmable timer, or an external clock source. Analog and digital outputs can also be synchronized to either of these clocks. Bus Mastering DMA is utilized to provide CPU and system-independent data transfers, insuring data acquisition performance irrespective of other system activities.

Scan Clock Sources: 2

1. Internal, programmable from 5 μs to 5.96 hours maximum in 5 μs steps
2. External, TTL level input up to 200 kHz maximum

Programmable parameters per scan: channel (random order), gain, unipolar/bipolar

Depth: 512 locations

On-board Channel to channel scan rate: 5 or 10 μs per channel, programmable

Expansion channel scan rate: 5 or 10 μs per channel, programmable

External Acquisition Scan Clock Input

Applicable to DaqBoard/2000, /2001, /2005, /2000c, /2001c, and /2005c

Maximum rate: 200 kHz

Signal Range: 0V to +5V

Input Characteristics: 100 Ω series, 20 pF to common and 10 k Ω to +5V

Input protection: ± 8 kV ESD clamp diodes parallel

Trigger Level: TTL

Slew Rate Requirement: 14 V/ μs minimum

Minimum pulse width: 50 ns high, 50 ns low

Triggering

Applicable to DaqBoard/2000, /2001, /2005, /2000c, /2001c, and /2005c

Trigger Sources: 6, individually selectable for starting and stopping an acquisition. Stop acquisition can occur on a different channel than start acquisition; stop acquisition can be triggered via modes 2, 4, 5, or 6 described below. Pre-trigger is supported with fixed or variable pre-trigger periods.

Single-Channel Analog Hardware Trigger: Any analog input channel can be software programmed as the analog trigger channel, including any of the 256 analog expansion channels.

Input Signal Range: Anywhere within range of the selected input channel

Trigger level: Programmable (11-bit resolution), including "window triggering."

Hysteresis: Programmable (11-bit resolution)

Latency: 5 μs maximum

Single-Channel Analog Software Trigger: Any analog input channel, including any of the 256 analog expansion channels, can be selected as the software trigger channel. If the trigger channel involves a calculation, such as with temperature, then the driver automatically compensates for the delay required to calculate the reading, resulting in a maximum latency of one scan period.

Input Signal Range: Anywhere within the range of the selected trigger channel

Trigger level: Programmable (16-bit resolution), including “window triggering”

Latency: One scan period maximum

Single-Channel Digital Trigger: A separate digital input is provided for digital triggering

Input Signal Range: -15V to +15V

Trigger level: TTL

Minimum pulse width: 50 ns high, 50 ns low

Latency: 5 μ s maximum

Digital Pattern Triggering: 8 or 16-bit pattern triggering on any of the digital input ports. Programmable for trigger on equal, above, below, or within or outside of a window. Individual bits can be masked for “don’t care” condition.

Latency: One scan period maximum

Counter/Totalizer Triggering: Counter/totalizer inputs can trigger an acquisition. User can select to trigger on a frequency or on total counts that are equal, above, below, or within/outside of a window.

Latency: One scan period maximum

Software Triggering: Trigger can be initiated under program control.

Analog Output

Applicable to DaqBoard/2000, /2001, /2003, /2004, /2000c, /2001c, /2003c, and /2004c

The analog output channels are updated synchronously relative to scanned inputs, and clocked from either an internal onboard clock, or an external clock source. Analog outputs can also be updated asynchronously, independent of any other scanning in the system. Bus mastering DMA provides CPU and system-independent data transfers, ensuring accurate outputs that are irrespective of other system activities. Streaming from disk or memory is supported, allowing continuous, nearly-infinite length, waveform outputs (limited only by available PC system resources).

Channels: DaqBoard/2000 and DaqBoard/2000c: 2 DAC channels (DAC0, DAC1)

DaqBoard/2001, /2003, /2004, /2001c, /2003c, /2004c:

4 DAC channels each (DAC0, DAC1, DAC2, and DAC3)

Resolution: 16 bits

Output voltage range: ± 10 V

Output current: ± 10 mA

Offset error: ± 0.0045 V maximum

Gain error: $\pm 0.01\%$

Update rate: 100 kHz maximum, 1.5 Hz minimum (no minimum with external clock)

Settling Time: 10 μ s maximum to 1 LSB for full-scale step

Clock Sources: 4

1. Onboard D/A clock, independent of scanning input clock
2. Onboard scanning input clock
3. External D/A input clock, independent of external scanning input clock
4. External scanning input clock

Digital I/O

Applicable to DaqBoard/2000, /2001, /2002, /2004, /2005, /2000c, /2001c, /2002c, /2004c and /2005c

Channels: 40, expandable to 208 with external DBK options

Input Scanning Modes: 2

1. Asynchronous, under program control at any time relative to input scanning
2. Synchronous with input scanning

Ports: 3 x 8-bit (82C55 emulation), and 1 x 16-bit. Each port is programmable as input or output.

Input Characteristics: 100 Ω series, 20 pF to common

Input protection: ± 8 kV ESD clamp diodes parallel

I/O levels: TTL

Sampling/Update rate: 200 kHz maximum

Pattern Generation Output

Applicable to DaqBoard/2000, /2001, /2002, /2004, /2005, /2000c, /2001c, /2002c, /2004c, and /2005c

The P3 16-bit digital I/O port can be configured for 16-bit pattern generation. The pattern can be updated synchronously with an acquisition from a file. If pattern generation mode is utilized, then the D/A outputs can only be used in an asynchronous mode. Bus mastering DMA provides CPU and system-independent data transfers, insuring data acquisition performance irrespective of other system activities. Streaming from disk or memory is supported, allowing continuous, nearly-infinite length, pattern outputs (limited only by available PC system resources)

Frequency/Pulse Generators

Applicable to DaqBoard/2000, /2001, /2002, /2004, /2005, /2000c, /2001c, /2002c, /2004c, /2005c

Channels: 2 x 16-bit

Output Waveform: Square wave

Output rate: 1 MHz base rate divided by 1 to 65535 (programmable)

High level output voltage: 2.0 V minimum @ -3.75 mA, 3.0 V minimum @ -2.5 mA

Low level output voltage: 0.4 V maximum @ 2.5 mA

Frequency/Pulse Counters

Applicable to DaqBoard/2000, /2001, /2002, /2004, /2005, /2000c, /2001c, /2002c, /2004c, and /2005c

Counter inputs can be scanned synchronously along with analog and digital scanned inputs, based either on internal programmable timer, or an external clock source. Bus mastering DMA provides CPU and system-independent data transfers, insuring data acquisition performance irrespective of other system activities. Counters can be configured to clear when read, or to totalize and clear under program control.

Channels: 4 x 16-bit, cascadable as 2 x 32-bit

Input rate: 10 MHz maximum

Input Signal Range: -15 V to +15 V

Input Characteristics: 2.7 k Ω series in parallel with 20 pF to common and 10 k Ω to +5 V

Input protection: ± 8 kV ESD clamp diodes parallel

Trigger Level: TTL

Minimum pulse width: 50 ns high, 50 ns low

Included Accessories and Software

Software: *Windows Drivers (32-bit), 90-day Getting Started DaqView*

Hardware: DBK205 is included with only DaqBoard/2003 and DaqBoard/2003c. This adapter option provides screw-terminal access to the board's four analog outputs (DAC0, DAC1, DAC2, and DAC3), 1 digital ground, 5 analog grounds, an external clock (CLK), and an external trigger (XTTL).

Optional Accessories

Software: DaqView including drivers for DasyLab and LabView, DIAdem-View post-acquisition software, DasyLab

Hardware:

- CA-37-x - Expansion cable. The “x” indicates number of devices on expansion side, for example, CA-37-1 is a DB37-to-DB37 cable that provides expansion to 1 card. CA-37 cables are used to connect from P1 to P1, P2 to P2, or P3 to P3.
- CA-195 - Interconnect cable, 3-ft, 100-conductor, mates with all above options and DaqBoard/2000 series DaqBoard/2000c series board P4 connectors.
- DBK200 - Adapter panel, for connection of DBK signal conditioning and expansion options (analog)
- DBK201 - Adapter panel, connects DBK signal conditioning and expansion options
- DBK202 - Adapter panel with screw terminals, connects DBK signal conditioning and expansion options
- DBK203 - Adapter module with screw terminals, connects DBK signal conditioning and expansion options
- DBK204 - Consists of a DBK203 and a CA-209 CE cable kit for meeting CE compliance
- DBK205 - (included with DaqBoard/2003). This adapter option provides screw-terminal access to DaqBoard/2003's and DaqBoard/2003c's four analog outputs (DAC0, DAC1, DAC2, and DAC3) 1 digital ground, 5 analog grounds, an external clock (CLK), and an external trigger (XTTL).
- DBK206 - Screw-terminal board suitable for both analog and digital expansion. It provides three DB37 connectors (P1, P2, and P3) and corresponding terminal blocks.
- DBK207 - Carrier board for 5B-compatible analog input modules. The DBK207 board includes two P1 connectors for analog expansion, a power connection terminal, and 16 signal terminal blocks.
- DBK207/CJC - Carrier board for 5B-compatible analog input modules. The DBK207 board includes two P1 connectors for analog expansion, a power connection terminal, 16 signal terminal blocks, and cold junction sensors for cold junction compensation (CJC) for thermocouple applications.
- DBK208 - Carrier board for Opto-22 compatible solid-state-relay (SSR) digital modules. The DBK208 board includes two P2 connectors for digital expansion, a power connection terminal, and 16 signal terminal blocks.
- DBK209 - mini-adapter board suitable for both analog and digital expansion. The board provides three DB37 connectors (P1, P2, and P3).
- DIN-DBK-1 – DIN-rail mount kit for DBK206, DBK207, and DBK208 applications.
- Rack-DBK-3 – Rack mount kit for DBK206, DBK207, DBK208, and DBK209 applications.

Manuals*

Manual Set (Set #1033), Programmer, DBK, Daq2K Series, p/n 1033-0900.

This is a hardcopy set of manuals that is available for purchase.
The set includes the following three manuals.

User's Manual for DaqBoard/2000 and DaqBoard/2000c (p/n 1033-0901)

Programmer's Manual for developing custom programs using API commands.
(p/n 1008-0901)

DBK Option Cards & Modules User's Manual. (p/n 457-0905)

*PDF versions of the manuals are included on your data acquisition CD and are automatically installed onto the host computer's hard drive as a part of product support. The default location is the Programs directory. The manuals can be read and printed using the Adobe Acrobat Reader®, which is also included on the CD.

DBK Basics

Introduction..... 1

How Do DBKs Connect to the Data Acquisition Device? 2

Connecting DBKs to DaqBooks, ISA-Type DaqBoards, and LogBooks 2

Connecting DBKs to Daq PC-Cards3

Connecting DBKs to DaqBoard/2000 Series and cPCI DaqBoard/2000c Series Boards 4

DBK Identification Tables 5

Analog Output DBKs 5

Digital I/O Control DBKs 5

Analog Signal Conditioning DBKs 5

Expansion and Terminal Panel Connection DBKs 6

Power Supply DBKs 6

Tips on Setting up a Data Acquisition System 7

Power Supplies and Power Connectors8

An Introduction to Power-Related DBKs 9

Calculating Your System's Power Needs 11

Additional Reading 13

CAUTION



Turn off power to all devices connected to the system before connecting cables or setting configuration jumpers and switches. Electrical shock or damage to equipment can result even under low-voltage conditions.

CAUTION



The discharge of static electricity can damage some electronic components. Semiconductor devices are especially susceptible to ESD damage. You should always handle components carefully, and you should never touch connector pins or circuit components unless you are following ESD guidelines in an appropriate ESD controlled area. Such guidelines include the use of properly grounded mats and wrist straps, ESD bags and cartons, and related procedures.

Introduction

The term “DBK” typically refers to a card or module that is used to expand or enhance a primary data acquisition device, such as a DaqBook, DaqBoard, or LogBook. As will be seen in the upcoming DBK identification tables, DBKs provide a wide variety of data acquisition functions. Depending on the DBKs used, one or more of the following can be realized:

- signal conditioning
- analog output
- digital I/O
- channel expansion
- supplying powering to another acquisition device
- providing an interface for different connectivity; for example, in a DaqBoard/2000 Series board, converting a P4, 100-pin connector to P1, P2, and P3 37-pin, DB37 connectors.



Reference Notes: During software installation, Adobe® PDF versions of user manuals will automatically install onto your hard drive as a part of product support. The default location is in the **Programs** directory, which can be accessed from the *Windows Desktop*. Refer to the PDF documentation, especially the *DBK Option Cards and Modules User's Manual* (p/n 457-0905) for details regarding both hardware and software in relevant to DBKs.

A copy of the Adobe Acrobat Reader® is included on your CD. The Acrobat Reader provides a means of reading and printing the PDF documents. Note that hardcopy versions of the manuals can be ordered from the factory.

How Do DBKs Connect to the Data Acquisition Device?

Each DBK connects to the primary data acquisition device; e.g., a DaqBook, DaqBoard, or LogBook, through one of three 37-pin ports, which are designated as follows:

- P1 – Analog I/O
- P2 – Digital I/O
- P3 – Pulse/Frequency/High-Speed Digital I/O

Depending on the primary data acquisition device, connectivity issues differ slightly. This will be made clear by the figures and accompanying text that follow.

Connecting DBKs to DaqBooks, ISA-Type DaqBoards, and LogBooks

For DaqBooks, ISA-Type DaqBoards, and LogBooks, DBK connections are not made directly to the port, but through a CA-37-x ribbon cable, where “x” indicates the number of expansion devices that can be connected. For example, in addition to providing a DB37 connector to interface with the primary data acquisition device, a CA-37-3 cable includes three additional DB37 connectors. These provide a means of adding three DBKs to one port. Use of a CA-37-16 cable will allow up to 16 DBKs to be added. The CA-37-x cable system is excellent for DaqBooks, LogBooks, and ISA-type DaqBoards.

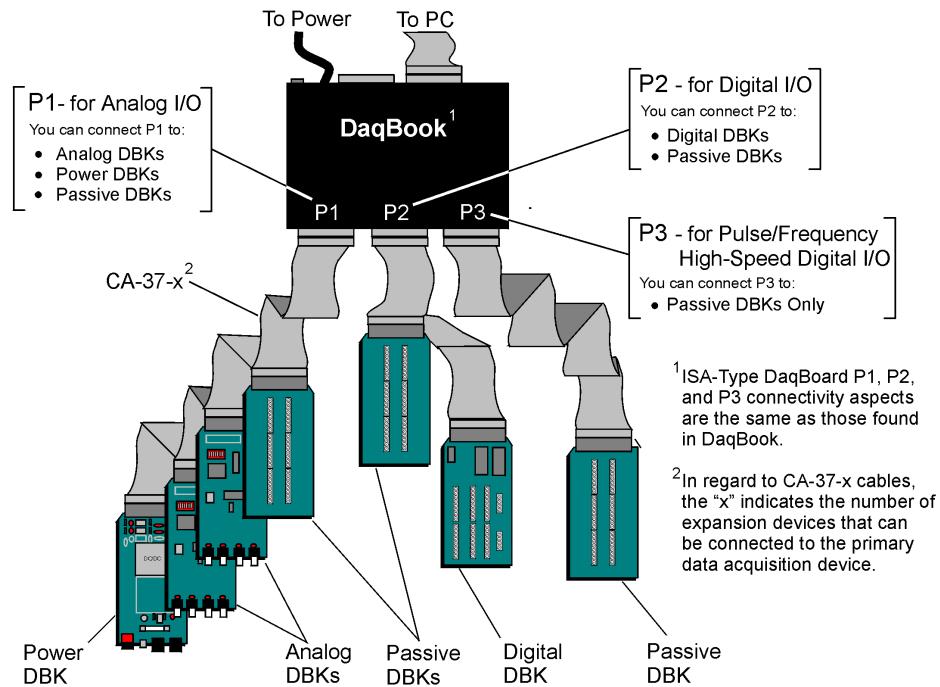

Connecting DBKs to a DaqBook

The above figure applies to LogBooks, DaqBooks, and ISA-type DaqBoards. As will be seen elsewhere in the documentation, some models do not include all three connectors (P1, P2, and P3).

Connecting DBKs to Daq PC-Cards

The Daq PC-Card is only intended for connections to a P1 connector of a single “passive” DBK card or module. A passive DBK card or module is one that provides a desired connectivity (such as BNCs or screw terminals), but performs no signal conditioning.

A CA-134 Interface Cable and a CN-86-F (dual DB37 female adapter) are used to provide the DB37, P1 connector.

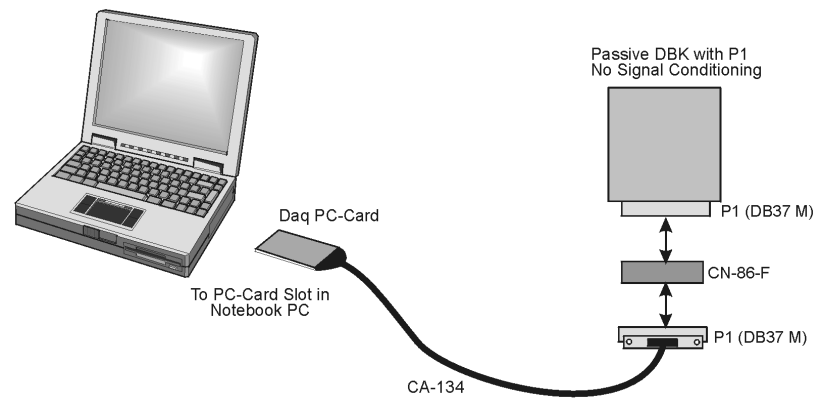

Daq PC-Card Cabling

The CA-134 cable connects to a CN-86-F adapter, which then connects to a single “passive” card or module. The passive DBKs are:

- **DBK1 – 16 Connector BNC Module**
- **DBK11A – Screw Terminal Option Card**
- **DBK40 – BNC Analog Interface**



Reference Note:

For information regarding the passive DBKs (DBK1, DBK11A, and DBK40), refer to the *DBK Option Cards and Modules User's Manual* (p/n 457-0905) for details regarding both hardware and software in relevant to DBKs.

Connecting DBKs to DaqBoard/2000 Series and cPCI DaqBoard/2000c Series Boards

DaqBoard/2000 Series and cPCI DaqBoard/2000 Series boards have 100-pin connectors designated as P4. The 100 pins correlate to various pins on P1, P2, and P3 DB37 connectors.* Connectivity in the system is as follows (see figure).

- Both the DaqBoard/2000 and /2000c Series board connect to a CA-195 cable. The cable has two, 100-pin, P4 connectors.
- The CA-195 connects to a DBK200 Series adapter board or adapter module for 100-pin to 37-pin adaptations, e.g., P4-to-P1, P2, P3; but not necessarily all three.*
- The DBK200 Series adapter connects to a CA-37-x ribbon cable, where “x” indicates the number of expansion devices that can be connected. For example, in addition to providing a DB37 connector to interface with the primary data acquisition device, a CA-37-3 cable includes three additional DB37 connectors. These provide a means of adding three DBKs to one port. Use of a CA-37-16 cable will allow up to 16 DBKs to be added.
- The CA-37-x cable connects to expansion DBKs, in accordance with port type. For example, Analog DBKs to port P1, Digital DBKs to port P2, and passive DBKs to port P3.

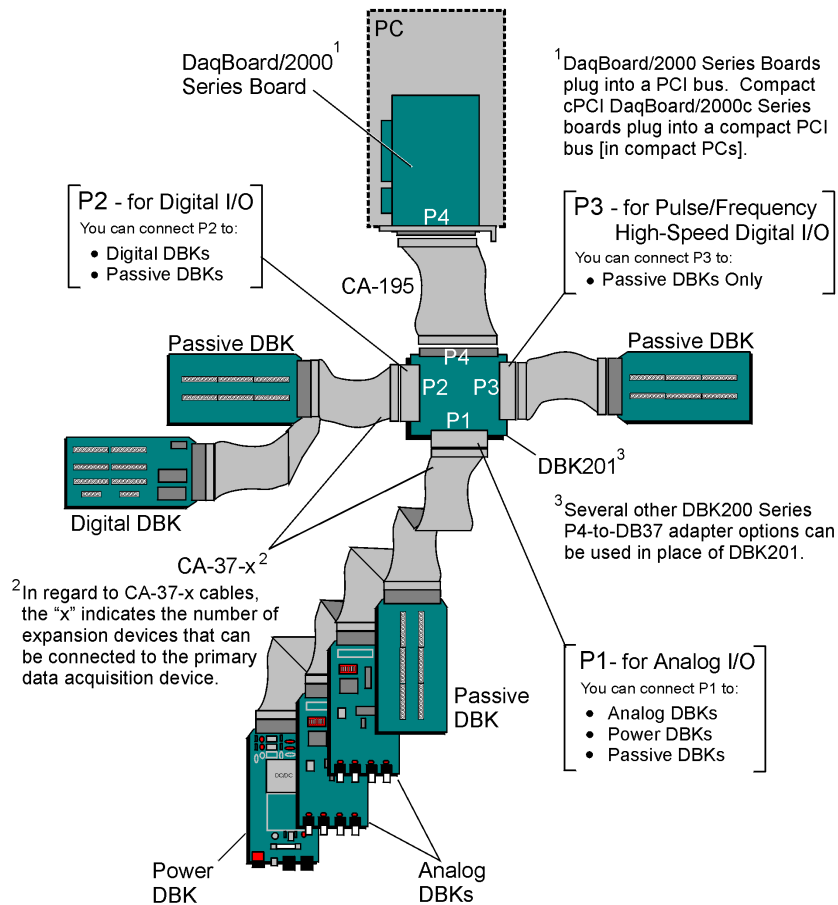

Connecting DBKs to a DaqBoard/2000 Series Board

* DaqBoard/2003 and cPCI DaqBoard/2003c are exceptions to the above connectivity method. The /2003 board typically connects directly to a DBK205 (P4-to-Screw Terminal Adapter), as discussed in the *DBK Option Cards and Modules User's Manual* (p/n 457-0905).

DBK Identification Tables

Analog Output DBKs

Analog Output			
Product	Name/Description	I/O	Connectivity
DBK2	Voltage Output Card	4 channels	P1
DBK5	Current Output Card	4 channels	P1

Digital I/O Control DBKs

Digital I/O / Control			
Product	Name/Description	I/O	Connectivity
DBK20	General-Purpose Digital I/O Card (Screw Terminals)	48 channels	P2
DBK21	General-Purpose Digital I/O Card (DB37 Connectors)	48 channels	P2
DBK23	Optically Isolated Digital-Input Module	24 channels	P2
DBK24	Optically Isolated Digital-Output Module	24 channels	P2
DBK25	Relay Output Card	8 channels	P2
DBK208	Carrier board for Opto-22 Compatible Solid-State-Relay Digital Modules.	Two 8-bit banks of SSR modules	Two P2s P4

Analog Signal Conditioning DBKs

The DBKs that are used for analog signal conditioning attach to transducers and condition their outputs into analog voltages. An A/D converter, located in the primary acquisition device, measures the analog voltages. There are many signal-conditioning solutions available (and more are in development). Note that DBK high-capacity modules require more circuitry than can fit on a compact card.

Analog Signal Conditioning			
Product	Name/Description	I/O	Connectivity ¹
DBK4	Dynamic Signal Input Card	2 channels	P1
DBK7	Frequency-to-Voltage Input Card	4 channels	P1
DBK8	High-Voltage Input Card	8 channels	P1
DBK9	RTD Measurement Card	8 channels	P1
DBK12	Low-Gain Analog Multiplexing Card Note 2	16 channels	P1
DBK13	High-Gain Analog Multiplexing Card Note 2	16 channels	P1
DBK15	Universal Current/Voltage Input Card Note 2	16 channels	P1
DBK16	Strain-Gage Measurement Card	2 channels	P1
DBK17	Simultaneous Sample & Hold Card	4 channels	P1
DBK18	Low-Pass Filter Card	4 channels	P1
DBK19	Thermocouple Card Note 2	14 channels	P1
DBK42	5B Isolated Signal-Conditioning Module	16 channels	P1
DBK43A	Strain-Gage Measurement Module	8 channels	P1
DBK44	5B Isolated Signal-Conditioning Card	2 channels	P1
DBK45	SSH and Low-Pass Filter Card	4 channels	P1
DBK50	Isolated High-Voltage Input Module	8 channels	P1
DBK51	Isolated Low-Voltage Input Module	8 channels	P1
DBK52	Thermocouple Input Module Note 2	14 channels	P1
DBK53	Low-Gain Analog Multiplexing Module Note 2	16 channels	P1
DBK54	High-Gain Analog Multiplexing Module Note 2	16 channels	P1
DBK70	Vehicle Network Interface, Analog Multiplexer Module	16 channels	P1
DBK80	Differential Voltage Input Card with Excitation Output	16 channels	P1
DBK81	Thermocouple Card, High-Accuracy	7 channels	P1
DBK82	Thermocouple Card, High-Accuracy	14 channels	P1
DBK83	Thermal Couple Card, High-Accuracy; uses Connection Pod	14 channels	POD-1
DBK84	Thermocouple Module, High-Accuracy	14 channels	P1
DBK207	Carrier Board for 5B Compatible Analog Input Modules	16 channels	Two P1s / P4
DBK207/CJC	Carrier Board for 5B Compatible Analog Input Modules. DBK207/CJC includes cold junction compensation (CJC)	16 channels	Two P1s / P4

Note 1: P1, P2, and P3 DB37 connectors do not exist on the DaqBoard/2000 Series or /2000c Series boards, but are obtained by using P4 adapters (DBK200 series). These adapters typically connect to the DaqBoard/2000 Series [/2000c Series] 100-pin P4 connector via a CA-195 cable.

Note 2: For DaqBoard/2000 and cPCI DaqBoard/2000 Series boards, internal clocks should be set to 100 kHz when used with any of the following DBK options: DBK12, DBK13, DBK15, DBK19, DBK52, DBK53, and DBK54. See specific DBK section for details.

Expansion and Terminal Panel Connection DBKs

The following DBKs offer provide various expansion and connection options. The stackable 3-slot DBK10 low-profile enclosure can be used for up to three DBKs. If a system has more than 3 DBKs, the 10-slot DBK41 can be used. Several DBK41s can be daisy-chained to accommodate many DBKs in one system.

Expansion and Connection, General			
Product	Name/Description	I/O	Connectivity
DBK1	16-Connector BNC Adapter Module	16 connectors	P1
DBK10	3-Slot Expansion Chassis	3 cards	P1, P2, or P3
DBK11A	Screw-Terminal Option Card (DB37-Screw Terminal Block)	Component sockets	P1
DBK40	BNC Interface	18 connectors	P1 or P3
DBK41	Analog Expansion Enclosure	10 cards	P1 or P2
DBK60	Expansion Chassis with Termination Panels	3 cards	P2

Termination Panels, Connectivity for DaqBoard/260			
Product	Name/Description	I/O	Connectivity ¹
DBK601	Termination Panel - blank rear panel	none	none
DBK602	Termination Panel - BNC rear panel	16 connectors	BNC
DBK603	Termination Panel - Safety Jacks, single ended	16 connectors	Safety Jacks
DBK604	Termination Panel - Safety Jacks, differential	8 differential (16)	Safety Jacks
DBK605	Termination Panels - Thermal Couple, differential panels; specify type: B, J, K, R, S, or T	16 differential	T/C Connectors
DBK606	Termination Panel – 3 Terminal Blocks; 16 connections per TB	48 connectors	Screw Terminal
DBK607	Termination Panel – strain relief clamp	none	none
DBK608	Termination Panel – 3 female DB37 connectors	three DB37	DB37

Several signal connection options were developed primarily for use with DaqBoard/2000 Series and cPCI DaqBoard/2000c Series Boards. The DBK200 Series P4-Adapter documentation provides the basic connection concepts. That information, along with the related DBK subsections should enable you to set up your desired configuration.

P4 Adaptive Connection for DaqBoard/2000 Series and cPCI DaqBoard/2000c Series			
Product	Name/Description	I/O	Connectivity ¹
DBK200	P4-to-P1 Adapter Board	P1	P4
DBK201	P4-to-P1/P2/P3 Adapter Board	P1, P2, P3	P4
DBK202	P4-to-P1/P2/P3 Adapter Board with Screw-Terminals	P1, P2, P3	P4
DBK203	A module version of DBK202	P1, P2, P3	P4
DBK204	A module version of DBK202 with an included CE cable kit.	P1, P2, P3	P4
DBK205	P4-to-TB1 12-slot Screw Terminal Block for DaqBoard/2003.	TB1, 12-slot	P4
DBK206	P4-to-P1/P2/P3 Adapter Board with Screw-Terminals	P1, P2, P3	P4
DBK209	P4-to-P1/P2/P3 Mini-Adapter Board	P1, P2, P3	P4

Note 1: P1, P2, and P3 DB37 connectors do not exist on the DaqBoard/2000 Series, or /2000c Series boards, but are obtained by using P4 adapters (DBK200 series). These adapters typically connect to the DaqBoard/2000 Series [/2000c Series] 100-pin P4 connector via cable.

Power Supply DBKs

Power supply type DBKs are typically used in laboratory, automotive, and field applications. Input power can come from any +10 to +20 VDC source, or from an AC source by using an appropriately rated AC-to-DC adapter. The DBK30A rechargeable power supply can power DBK modules where AC mains are not available (the DBK30A outputs 28 V for powering transducers). For a large number of DBK cards, the DBK32A or DBK33 can be installed into an expansion slot. The DBK33 is used when +5 V is required in addition to ± 15 VDC. The DBK34 provides a steady 12 or 24 VDC while working with vehicle electrical systems that may be turned on or off during testing.

Power Supply		
Product	Name/Description	Power
DBK30A	Rechargeable Battery/Excitation Module	+12-14, 24-28 VDC (3.4 A-hr @ 14 VDC)
DBK32A	Auxiliary Power Supply Card	± 15 V @ 500 mA
DBK33	Triple-Output Power Supply Card	± 15 V @ 250 mA; +5 V @ 1 A
DBK34	Vehicle UPS Module	12/24 VDC (5 A-hr @ 12 VDC)
DBK34A	UPS Battery Module	12/24 VDC (5 A-hr @ 12 VDC)

Tips on Setting up a Data Acquisition System

A successful installation involves setting up equipment and setting software parameters. In addition to this manual, you may need to consult your Daq device or LogBook user's manual.

DBKs should be configured before connections are made and power is applied. This sequence can prevent equipment damage and will help ensure proper operation on startup. Many DBKs have on-board jumpers and/or DIP switches that are used for setting channels and other variables. You will need to refer to the individual DBK document modules to ensure that the DBKs are properly configured for your application.

Prior to designing or setting up a custom data acquisition system, you should review the following tips. After reviewing the material you can write out the steps to setup a system that will best meet your specific application needs.

1. The end use of the acquisition data should be used to determine how you set up and program your acquisition system. Prior to creating the system you should understand its layout and know how you are going to assign the channels. If you can answer the following questions you are off to a good start. If not, you need to find the answers.
 - What engineering units, ranges, sampling rates, etc. are best for your data?
 - Will the data be charted graphically, statistically processed, or exported to other programs?
 - How will the data be used?
 - How will the data be saved?
 - What are your system's power requirements? Using several DBKs or transducers that require excitation current may require an extra power supply, e.g., a DBK32A.
2. Assign channel numbers.
3. Plan the location of transducers, cable runs, DBKs, the acquisition device [LogBook or Daq device], and the computer. Label your transducers, cables, and connectors to prevent later confusion.
4. When configuring your LogBook or Daq device(s) consider the following:
 - LogBook calibration is typically performed automatically through LogView software; however, some DBKs may require manual calibration.
 - **The DaqBook and DaqBoard (ISA type) have internal jumpers and switches that you must set manually to match your application.**
 - Some DaqBook models are partially configured in software.
 - Daq PC-Cards are configured entirely in software.
 - DaqBoard/2000 Series boards are PCI type boards. They have no jumpers or switches and are configured entirely through software.
 - cPCI DaqBoard/2000c Series boards are *compact* PCI (cPCI) type boards. They have no jumpers or switches and are configured entirely through software.
 - You may need to refer to other documentation, such as Quick Starts, Installation Guides, User's Manuals, and pertinent DBK document modules.
5. **Perform all hardware configurations before connecting signal and power. Remember to configure all the DBK cards and modules for your application. Several jumpers and DIP switches may need to be set (channel, gain, filters, signal mode, etc).**
6. Setting up channel parameters often requires both hardware and software setup.
7. Route and connect all signal and power cables while all power is turned OFF.
8. To minimize electrical noise, route all signal lines away from any RF or high-voltage devices.
9. Follow your device's specific installation instructions. For certain devices software should be installed first; for others, hardware should be installed prior to software installation.

10. **After software is loaded, remember to set the software parameters as needed for your application. The software must recognize all the hardware in the system. Measurement units and ranges should be checked to verify that they meet your application requirements.**
11. Remember to set all channels to the proper mode for your DBK or other signal source.
12. After your system is up and running, verify proper data acquisition and data storage.
13. Verify system accuracy; adjust ranges or calibrate as needed.
14. Device specific information regarding system setup and expansion can be found in the Daq and LogBook User's manuals; and in the applicable DBK document modules of this manual.
15. **If you are considering system expansion**, review the DBK10, DBK41, and DBK60 document modules. The best option depends on the number of DBK cards in your system. For just a few cards, use the stackable 3-slot DBK10 low-profile expansion enclosure. For more than six cards, use the 10-slot DBK41. DBK41s can be daisy-chained to one-another to handle a large number of DBKs.
16. **In regard to power management**, you should review the DBK30A, DBK32A, and DBK33 document modules. For portable applications, the compact DBK30A rechargeable power supply can provide power to the DBK10 or DBK41. The DBK30A also includes a 28 V output for powering 4 to 20 mA transducers. For applications with many DBK cards (initially or in future expansion), the DBK32A or DBK33 can be installed into any expansion slot. The DBK32A provides ± 15 VDC and the DBK33 provides ± 15 VDC and +5 VDC.

Power Supplies and Connectors



Power supplies convert the raw power they receive into a lower DC voltage and/or current for use by devices with various power demands. Many of the power supplies that are used to power data acquisition equipment are of the *switching-mode* type. These devices provide a regulated output whether the power supply's input is, for example, 60 Hz, 120 VAC as in the United States or, 50 Hz, 220 VAC as found in European countries. Small power supplies, that do not switch, consist of simple transformer/rectifiers and filtered capacitors; and operate over a smaller voltage range.

LogBooks - The switching-mode power supply commonly used with LogBook systems uses an input range of 100 VAC to 240 VAC at 50 Hz to 60 Hz. The power supply's output [to the LogBook] is 15 VDC @ 2.7 amps via a DIN5 connector.

DaqBooks - Power supplies that are used with DaqBooks are typically of the transformer/rectifier type. They supply the DaqBook with 15 VDC @ 900 mA via a DIN5 connector.

DBKs - The following table indicates the type of power supply that is typically used with certain DBKs.

15 VDC @ 2700 mA Switching-Mode Type Power Supply		15 VDC @ 900 mA Transformer/Rectifier Type, Unregulated Power Supply	
The DBKs in this column use up to 15 VDC @ 2700 mA. This <i>switching-mode</i> power supply receives power from a 100 to 240 VAC source, at 50 to 60 Hz, and converts it to the required value.		The DBKs in this column use up to 15 VDC @ 900 mA. This transformer/rectifier type power supply receives power from a 110 to 125 VAC source, at 60 Hz, and converts it to the required value.	
DBK	Description	DBK	Description
DBK32A	Auxiliary Power Supply Card	DBK23	Optically Isolated Digital-Input Module
DBK33	Triple-Output Power Supply Card	DBK24	Optically Isolated Digital-Output Module
DBK42	5B Isolated Signal Conditioning Module	DBK43A	Strain Gage Measurement Module
DBK70	Vehicle Network Interface	DBK50	Isolated High-Voltage Input Module
		DBK51	Isolated Low-Voltage Input Module

The DIN5 is the system's basic power connector (see the following figure). The CA-115 is a 6-in. cable with a plug (male) DIN5 connector on both ends. The CA-115 is used to connect DBK32As [or DBK33s] in parallel when they are to be powered by the same power supply.

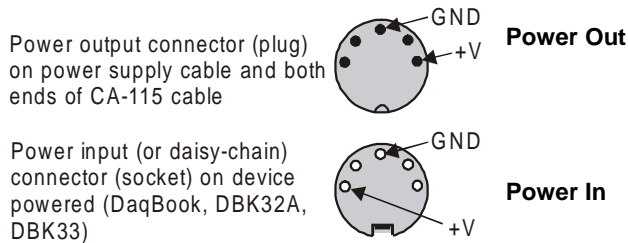

DIN5 Power Connectors

Note: DIN5 connectors for LogBook, DBK34, and DBK34A have threaded retaining rings.

Note: The following figure shows the pinout for the DBK34 and DBK34A Power Out DIN5 connector. The 28 V pin is only active when the device is in the 28 VDC mode; however, the 14 V pin is active regardless of the mode selected.

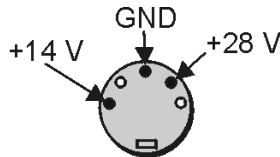

DIN5 Power Out
On a DBK34 and DBK34A

An Introduction to Power-Related DBKs

The power-related DBK options are the DBK30A, DBK32A, DBK33, DBK34, and DBK34A. From the standpoint of providing reliable power, these DBKs have proven convenient in laboratory, automotive, and field applications.

Input power for these devices can come from any 10 to 20 VDC source, or from an AC source via an appropriate AC-to-DC adapter.

A brief synopsis of the DBK power options follows. Refer to the respective document modules for complete information.



DBK30A module - provides power at 14 and 28 VDC with a rated capacity of 3.4 A-hr @ 14 VDC.

The DBK30A's 28 V output will power 4 to 20 mA transducers. The module's rechargeable power supply can power DBK modules in situations where AC mains are not available.

Note: Some transducers (e.g., 2-wire 4-20 mA transmitters, bridge-configured sensors, etc) require an excitation voltage in order to work properly. The DBK30A supplies 14 and 28 VDC. Consult transducer documentation before applying power.

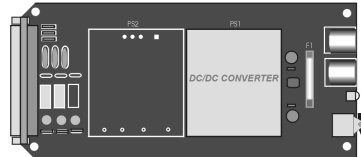
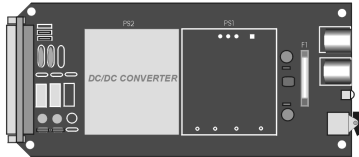

DBK32A - provides ± 15 VDC @ 500 mA.

DBK33 - provides ± 15 VDC @ 250 mA and +5 VDC @ 1000 mA.

The DBK32A and DBK33 power cards attach directly to the P1 analog expansion bus where they supply power to DBK analog expansion cards. The DBK32A and the DBK33 can be powered from an included AC adapter, an optional DBK30A battery module, or from a +10 to +20 VDC source such as a car battery.

When installed in a DBK10 three-slot expansion chassis, the DBK32A or DBK33 supplies power to the analog DBK [that is to receive power] via a CA-37-x cable.

If used with the DBK41 ten-slot expansion enclosure, the DBK32A or DBK33 installs into one of the analog expansion slots on the DBK41's backplane. A power card in any DBK41 slot (other than the leftmost, when viewed from the rear) will power the other cards that are connected to the DBK41's backplane.

CAUTION

If using a DBK32A or a DBK33 with a DaqBook or DaqBoard [ISA type], you must entirely remove the shunt jumpers from JP1. Failure to do so will result in damage to the 8254 timer chip. Refer to the power card document modules and to the *Daq device Hardware* sections of the DaqBook and DaqBoard [ISA] user's manuals for JP1 location and configuration.

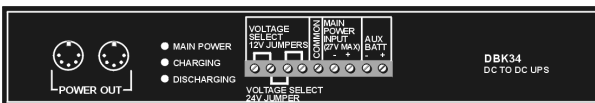

DBK34 module – provides 12 or 24 VDC with a 5.0 or 2.5 A-hr capacity (respectively). This module is an Uninterruptable Power Supply (UPS) that can be used for in-vehicle testing where the vehicle's electrical system will not affect acquisition device power during starter-current surge, or power-off.

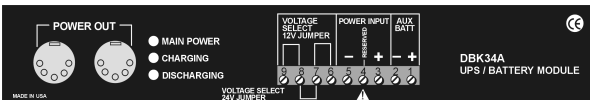

DBK34A module – provides 12 or 24 VDC with a 5.0 or 2.5 A-hr capacity (respectively). This device is classified as a UPS / Battery module. It is an improved version of the earlier DBK34. Like the DBK34, the DBK34A can be used for in-vehicle testing where the vehicle's electrical system will not affect acquisition device power during power during starter-current surge, or power-off.

Calculating Your System's Power Needs

Use the chart below and the worktable on the next page to ensure your system will have sufficient power. If the load (calculated in the worktable) exceeds available power (from the chart at the right), you must add a power card or a module such as a DBK32A or DBK33.

Available Power Chart—Supply	
Product	Available Power
LogBook	+5 VDC @ 0.10 A from P1-1, P2-18, P2-20, P3-20 +15 VDC @ 0.15 A from P1-21 +15 VDC @ 0.05 A from P3-19 -15 VDC @ 0.15 A from P1-2 -15 VDC @ 0.05 A from P3-37
DaqBook/100	2100 mW
DaqBook/112	2400 mW
DaqBook/120	2100 mW
DaqBook/200	4000 mW
DaqBook/216	4000 mW
DaqBook/260	4000 mW
DaqBoard/100A	3300 mW
DaqBoard/112A	3300 mW
DaqBoard/200A	3000 mW
DaqBoard/216A	3000 mW
DaqBoard/260A	3000 mW
DaqBoard/2000 Series & /2000c Series	5000 mW; 5 V at 1 A; ± 15 V at 75 mA each (with exception of DaqBoard/2002 and /2002c)
Daq PC-Card/112B	0 mW
Daq PC-Card/216B	0 mW
DBK32	7500 mW
DBK32A	15000 mW
DBK33	7500 mW
DBK34	5 A-hr in 12 V mode; fused at 8 A
DBK34A	5 A-hr in 12 V mode; fused at 8 A

Use the following procedure and table to calculate the required system power.

1. In the Quantity column (5th), list the number of DBKs of that type in your system.
2. In the Sub Total column (7th), enter the product of column 5 and column 6 (mW).
3. Add the Sub Total column, and enter the sum at the bottom right of the table.
This result is your power requirement in mW.



DBK32, DBK32A, and DBK34 cannot supply +5 VDC.

In cases that require +5 VDC, if the +5 VDC requirement exceeds 500 mW from a LogBook or Daq device, then a DBK33 must be used. Note that DBK33 can supply 1000 mW at +5 VDC.

Note: The DBK34 has an 8 amp fuse, and has a capacity of 5 A-hr when in the 12V mode, and a capacity of 2.5 A-hr when in the 24V mode.

DBK Power Requirement Worktable—Demand						
DBK Options	Voltage Reference			Calculation		
	+15 VDC	-15 VDC	+5 VDC	Quantity	× mW	= Sub Total
DBK1	0	0	0		0	
DBK2	18 mA	18 mA	5 mA		565	
DBK4	95 mA	80 mA	25 mA		2750	
DBK5	2 mA	2 mA	15 mA		135	
DBK7	14 mA	8 mA	18 mA		420	
DBK8	15 mA	15 mA	<1 mA		455	
DBK9	21 mA	16 mA	<1 mA		560	
DBK11A	0	0	0		0	
DBK12	15 mA	15 mA	<1 mA		455	
DBK13	15 mA	15 mA	<1 mA		455	
DBK15	16 mA	16 mA	<1 mA		485	
DBK16	37 mA	32 mA	<1 mA		1040	
DBK17	30 mA	30 mA	<1 mA		905	
DBK18	36 mA	36 mA	<1 mA		1085	
DBK19	6 mA	7 mA	<1 mA		200	
DBK20	0	0	<10 mA		50	
DBK21	0	0	<10 mA		50	
DBK23***	0	0	<2 mA		10	
DBK24***	0	0	<2 mA		10	
DBK25	0	0	<2 mA		10	
DBK40	0	0	0		0	
DBK41	0	0	0		0	
DBK42	<1 mA	<1 mA	<1 mA		35	
DBK43A***	<1 mA	<1 mA	<1 mA		35	
DBK44	<1 mA	<1 mA	60 mA (Note 1)		330	
DBK45	52 mA	52 mA	<1 mA		1565	
DBK50***	<1 mA	<1 mA	<1 mA		35	
DBK51***	<1 mA	<1 mA	<1 mA		35	
DBK52	6 mA	7 mA	<1 mA		200	
DBK53	15 mA	15 mA	<1 mA		455	
DBK54	15 mA	15 mA	<1 mA		455	
DBK70***	<1 mA	<1 mA	<1 mA		35	
DBK80	25 mA	25 mA	<1 mA		755	
DBK81	35 mA	35 mA	<2 mA		1060	
DBK82	60 mA	60 mA	<2 mA		1810	
DBK83	60 mA	60 mA	<2 mA		1810	
DBK84	60 mA	60 mA	<2 mA		1810	
Total Power Requirement in mW						
<p>Note 1: DBK44's 60 mA value is based on 30 mA for each of two 5B modules. This value will be higher if using 5B module 5B38 (200 mA for each 5B38), or if using 5B39 (170 mA for each 5B39). Refer to the DBK44 document module for more information.</p> <p>Note 2: DBK2 and DBK5 are not used with LogBook.</p> <p>*** Three asterisks indicate that the DBK is a module with internal power supply; powered separately.</p>						

Additional Reading

During software installation, Adobe® PDF versions of user manuals will automatically install onto your hard drive as a part of product support. The default location is in the **Programs** directory, which can be accessed from the *Windows Desktop*. Refer to the PDF documentation for details regarding both hardware and software.

A copy of the Adobe Acrobat Reader® is included on your CD. The Reader provides a means of reading and printing the PDF documents. Note that hardcopy versions of the manuals can be ordered from the factory.

You should refer to the following documents, as applicable, for acquisition system and programming information.

- *DBK Option Cards and Modules User's Manual* (p/n 457-0905)
- *DBK70 User's Manual* (p/n 1056-0901)
- *DaqBoard [ISA] User's Manual* (p/n 457-0907)
- *DaqBook User's Manual* (p/n 457-0906)
- *Daq PC-Card User's Manual* (p/n 457-0908)
- *DaqBoard/2000 Series and cPCI DaqBoard/2000c Series User's Manual* (p/n 1033-0901)
- *LogBook User's Manual* (p/n 461-0901)
- *Programmer's Manual* (p/n 1008-0901)
- *Post Acquisition Data Analysis User's Guide*

Of the above listed documents, the most relevant to the DBKs is the *DBK Option Cards and Modules User's Manual* (p/n 457-0905). A synopsis of the contents follows:

- 1 – Introduction to DBKs.** Explains what DBKs are and uses tables to identify the various types of DBKs. The chapter includes tips for setting up a data acquisition system, discussions of signal management and signal conditioning, and CE compliance information.
 - 2 – Power Management.** Explains how to determine system power requirements and discusses various power options.
 - 3 – System Connections and Pinouts.** Provides instructions for connecting a DBK option to a Daq or LogBook device. Pinouts are included for the P1, P2, and P3 DB37 connectors, as well as the 100-pin P4 connector used by PCI and compact PCI (cPCI) boards.
 - 4 – DBK Set Up in DaqView.** Provides instruction for setting up analog and digital DBKs in *DaqView's Hardware Configuration* screen.
 - 5 – DBK Set Up in LogView.** Provides instruction for setting up analog and digital DBKs in *LogView's Hardware Configuration* window.
 - 6 – Troubleshooting.** Explains solutions to common noise, wiring, and configuration problems.
- DBK Document Modules** –Includes DBK-specific documentation for the card and module options listed on pages 5 and 6 of this document.



Overview 2-1

DBK200 Series, P4 Connector Options 2-2

Pinouts for DaqBoard/2000 Series and /2000c Series Boards 2-7

CAUTION



Turn off power to all devices connected to the system before connecting cables or setting configuration jumpers and switches. Electrical shock or damage to equipment can result even under low-voltage conditions.

CAUTION



The discharge of static electricity can damage some electronic components. Semiconductor devices are especially susceptible to ESD damage. You should always handle components carefully, and you should never touch connector pins or circuit components unless you are following ESD guidelines in an appropriate ESD controlled area. Such guidelines include the use of properly grounded mats and wrist straps, ESD bags and cartons, and related procedures.

Overview

DaqBoard/2000 Series and DaqBoard/2000c Series boards communicate [external from the host PC] through the board's 100-pin P4 connector. Typically, a DBK200 Series P4-adapter is used to provide one or more DB37 connectors (P1, P2, P3), which are subsets of the 100-pin P4 connector.

Pinouts for P1, P2, P3, and P4 are located after the following DBK200 Series board descriptions.

DaqBoard/2000 Series and cPCI DaqBoard/2000c Series boards communicate [external from the host PC] through the board's 100-pin P4 connector. Typically a DBK200 Series P4-adapter is used to provide one or more DB37 connectors (P1, P2, P3).

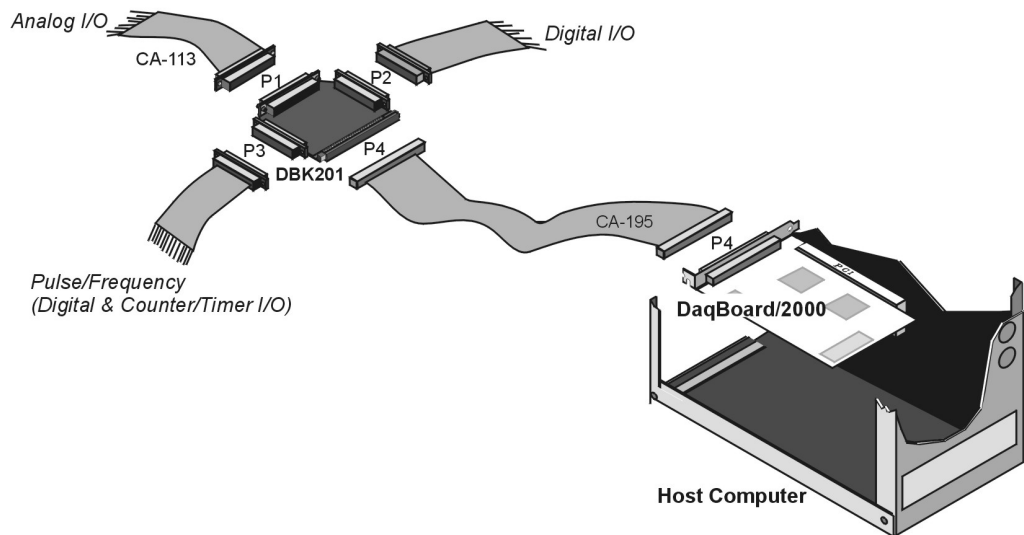

Using a DBK201 P4-to-P1/P2/P3 Adapter

The following matrix provides a quick comparison of the DBK200 Series adapter boards. Details for each board are provided in the *DBK Option Cards and Modules User's Manual* (p/n 457-0905). An illustration and brief discussion of each DBK200 Series adapter board is presented after the following table.

DBK200 Series, Adapter Board Matrix							
DBK	P1 Analog	P2 Digital	P3 Pulse, Freq., Digital	P4	Screw Term- inals	Special Features	Comments
200	Yes	No	No	Yes	No	No	Analog I/O use only.
201	Yes	Yes	Yes	Yes	No	No	Like DBK209, except for form-factor.
202 203 204	Yes	Yes	40-pin header for P3	Yes	Yes	Custom RC Filter Setup.	DBK202 is a bare board. DBK203 consists of a DBK202 mounted in a chassis. DBK204 consists of a DBK203 and a CA-209 CE cable kit.
205	No	No	12 screw- term.	Yes	Yes	No	Only used with DaqBoard/2003 or /2003c. Can plug directly into P4. Screw terminals are related to P3.
206	Yes	Yes	Yes	Yes	Yes	No	Similar to DBK202, but has a different form-factor and has no RC filter setup.
207 207/CJC	Yes (Qty. 2)	No	No	Yes	Yes	Can carry 5B modules.	Supports 5B-compatible Analog I/O modules. DBK207/CJC includes Cold Junction Compensation. Includes two P1 connectors. Screw terminals are for 5B module connections.
208	No	Yes (Qty. 2)	No	Yes	Yes	Can carry relay modules.	Supports Opto-22 compatible Solid-State-Relay (SSR) digital modules. Includes two P2 connectors.
209	Yes	Yes	Yes	Yes	No	No	Like DBK201, except for form-factor.

DBK200 Series, P4 Connector Options



Reference Note: Prior to connecting a DBK to a DaqBoard/2000 Series or /2000c Series board, refer to the applicable DBK document module(s), in the *DBK Option Cards and Modules User's Manual* (p/n 457-0905). During software installation, the manual is automatically installed onto your hard drive as a part of product support. The default location is the **Programs** directory, which can be accessed through the Windows Desktop.

DBK200

The DBK200 P4-to-P1 adapter board provides a DB37 P1 connector.

P1 is suitable for ANALOG/IO.

DBK200 does not support Digital I/O or frequency signals.

DBK200's P4 (100-pin connector) connects to the DaqBoard/2000 Series or DaqBoard/2000c Series board's P4 connector via a CA-195 Cable.

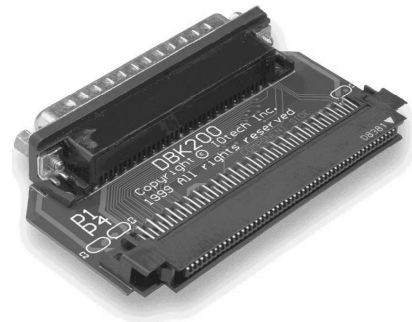

DBK200 Adapter with P1

DBK201

The DBK201 P4-to-P1/P2/P3 adapter provides DB37 P1, P2, and P3 connectors.

- P1 is used for ANALOG I/O.
- P2 is used for DIGITAL I/O.
- P3 is used for Pulse/Frequency (Digital and Counter/Timer) I/O.

DBK201's P4 (100-pin connector) connects to a DaqBoard/2000 Series or /2000c Series board's P4 connector via a CA-195 Cable.

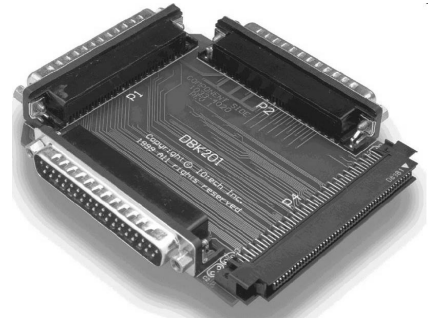

DBK201, P4-to-P1/P2/P3 Adapter

DBK202, DBK203, and DBK204

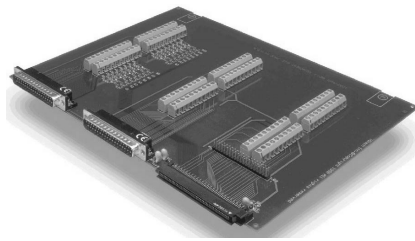

DBK202

P4-to-P1/P2/P3 Adapter with Screw-Terminals and Locators for RC Filter Setup



DBK203, with Cover Plate Removed¹

Chassis-Mounted P4-to-P1/P2/P3 Adapter with Screw-Terminals and Locators for RC Filter Setup

¹ **Note:** The DBK203, DBK204, and DBK204c modules are identical. The DBK204 designation indicates that the module includes a CE cable kit for use with DaqBoard/2000 Series boards that are of the standard PCI type. The DBK204c designation indicates that the module includes a CE cable kit for use with the compact-PCI type boards, i.e., the DaqBoard/2000c Series.

The DBK202, DBK203, DBK204, and DBK204c adapters each provide a DB37 P1 connector, DB37 P2 connector, and a 40-pin header (designated as P3).

- P1 is used for ANALOG I/O
- P2 for DIGITAL I/O
- P3 for Pulse/Frequency (Digital and Counter/Timer) I/O

In addition to the P1, P2, and P3 connectors, these boards include terminal blocks designated TB1 through TB12. The blocks provide a screw-terminal connection option for P1, P2, and P3.

Each of the three adapters can be connected to the DaqBoard/2000 Series or /2000c Series 100-pin P4 connector via a CA-195 cable.

Note: These screw-terminal adapter boards provides a means of connecting signals to a DaqBoard/2000 Series or a /2000c Series board through one of three methods:

- Cables connected to P1, P2, and P3 connectors, as applicable.
- Signal wires connected to the appropriate screw-terminal blocks (TB1 through TB12). The board's silkscreen identifies all screw terminals.
- With a combination of the above two methods.

Note: Board images are not to the same scale.

DBK205

The DBK205 provides 12 screw-terminal connections on one terminal block (TB1) for DaqBoard/2003 and DaqBoard/2003c. The signal lines on DBK205's P4 connector correspond with *P3-associated pins* on the P4 connector of DaqBoard/2003 and /2003c. The DBK205 can connect directly to the 100-pin P4 connector on the DaqBoard/2003, or DaqBoard/2003c.

DBK205
Terminations

TB1-1	AGND
TB1-2	DAC0
TB1-3	AGND
TB1-4	DAC1
TB1-5	AGND
TB1-6	DAC2
TB1-7	AGND
TB1-8	DAC3
TB1-9	AGND
TB1-10	XTTL
TB1-11	CLK
TB1-12	DGND

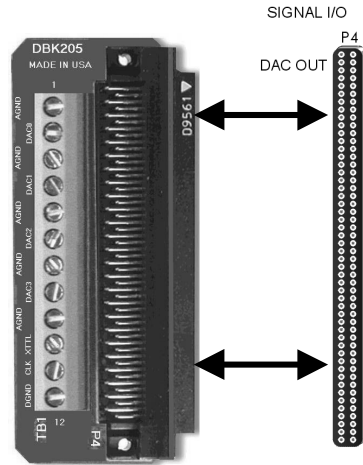

DBK205 Adapter

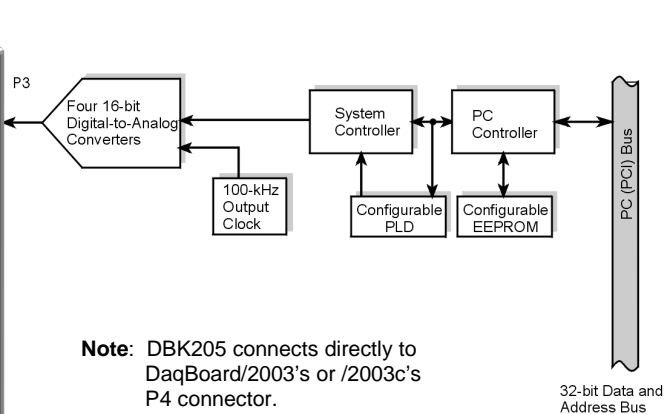

Note: DBK205 connects directly to DaqBoard/2003's or /2003c's P4 connector.

DaqBoard/2003 Block Diagram

DBK206

The DBK206 provides a P1, P2, and P3 connector and corresponding screw-terminal blocks.

- P1 is used for ANALOG I/O
- P2 for DIGITAL I/O
- P3 for Pulse/Frequency (Digital and Counter/Timer) I/O

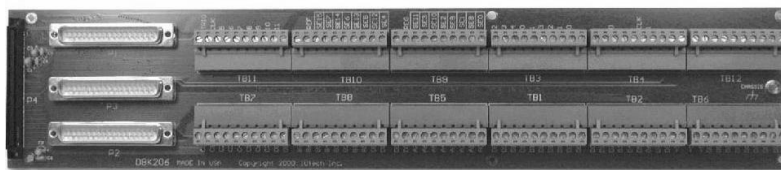

DBK206, P4-to-P1/P2/P3 Adapter with Screw-Terminals

The DBK206 is suitable for both analog and digital expansion. Signal connection to a DaqBoard/2000 Series or to a DaqBoard/2000c Series board can be made as follows:

- With cables connected to P1, P2, and P3 connectors, as applicable.
- With signal wires connected to the appropriate screw-terminal blocks (TB1 through TB12). Note that the DBK206 board's silkscreen identifies all screw terminals.
- With a combination of the above two methods.

Regardless of which method is used, the DBK206 connects to the 100-pin P4 connector of a DaqBoard/2000 Series or a /2000c Series board. The connection is made via a CA-195 cable. The board contains mounting holes that allow the board to be secured inside a user-provided enclosure.

Note: Board images are not to the same scale.

DBK207 and DBK207/CJC

The DBK207 and DBK207/CJC are carrier boards for 5B-compatible analog input modules. They each provide:

- two P1 connectors – for ANALOG I/O
- a 5 VDC power terminal
- footprints for sixteen 5B Modules
- 16 terminal blocks.

In addition, DBK207/CJC provides Cold Junction Compensation. The DBK207 and DBK207/CJC each include a 100-pin P4 connector for use with DaqBoard/2000 Series and cPCI DaqBoard/2000c Series Boards.

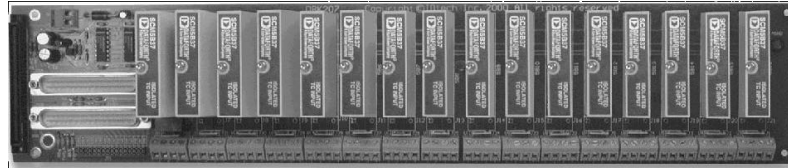

DBK207/CJC Carrier Board for 5B Compatible Modules

WARNING



Ensure that hard-wire emergency over-ride circuitry exists for all applications that make use of dangerous switch-loads. Do not operate such switch-loads unless emergency over-ride circuitry is present.

DBK207 and DBK207/CJC are typically installed in NEMA-type panels; however, they may be installed on DIN rails. Separate mounting instructions are included with Rack Mount Kit (part no. Rack-DBK-3) and with DIN-rail Mount Kit (part no. DIN-DBK-1).

DBK207 and DBK207/CJC allow Daq-based acquisition systems to use various combinations of sixteen 5B signal-conditioning modules. 5B modules can accommodate a variety of signals, including low-level thermocouple and strain-gage signals. Configuration options are flexible. You can select the type of signal attached to each channel. One Daq device can support up to 16 DBK207 [or DBK207/CJC] boards, providing a maximum of 256 isolated, analog input channels. Note that Daq devices scan the channels at the same 10 μ s/channel rate as other DBKs (256 scans in 2.56 ms in a full system).

Each user-installed 5B module offers 500 V isolation from the system and between channels. Both DBK207 and DBK207/CJC include 16 screw-terminal blocks for signal inputs. In addition, the DBK207/CJC includes cold junction compensators (CJCs) for use with thermocouple 5B modules. Sockets are provided for user-installed AC1362 current-sense resistor modules, as discussed in [5B Module Connection](#) in the DBK207 section of the *DBK Option Cards and Modules User's Manual* (p/n 457-0905).

DBK208

DBK208 is a two-bank carrier board for optically-isolated Solid-State-Relay (SSR) modules. Each bank supports up to eight digital I/O modules. The banks can be independently set as “input” or “output” via jumpers (JP0 for Bank 0, and JP1 for Bank 1). The I/O modules are industry standard Opto-22 compatible, 5-volt logic level modules.

The DBK208 provides:

- two P2 connectors for DIGITAL I/O
- footprints for sixteen optically-isolated Solid-State-Relay (SSR) Modules
- 16 dual-screw terminal blocks.

DBK208 includes a 100-pin P4 connector for use with DaqBoard/2000 Series and /2000c Series Boards.

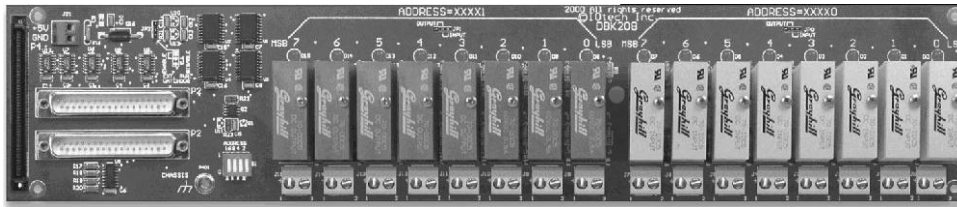

DBK208 Carrier Board for Opto-22 Compatible Solid-State-Relays

WARNING



Ensure that hard-wire emergency over-ride circuitry exists for all applications that make use of dangerous switch-loads. Do not operate such switch-loads unless emergency over-ride circuitry is present.

Note: DBK208 is not used with DaqBoard/2003.

DBK208 boards are typically installed in NEMA-type panels; however, they may alternatively be installed on DIN rails. Separate mounting instructions are included with Rack Mount Kit (part no. Rack-DBK-3) and with DIN-rail Mount Kit (part no. DIN-DBK-1).

In regard to the DaqBoard/2000 Series and DaqBoard/2000c Series boards, control originates in the board's 100-pin P4 connector. Connection of these boards to DBK208 can be made directly or indirectly as follows:

- Direct connection can be made from the DaqBoard/2000 Series or /2000c Series board's 100-pin P4 connector to a DBK208's P4 connector via a CA-195 cable.
- Indirect connection can be made using an additional DBK200 Series P4-adaptor that includes a 37-pin P2 connector. For example, one of the following could be used: DBK201, DBK202, DBK203, DBK204, DBK206, DBK209, or another DBK208. CA-37 cables are used to connect from P2 to P2.

Note that a single Daq-based data acquisition system can support up to 16 DBK208 boards, providing a total of 256 channels. DBK208 boards contain two DB37 P2 connectors for the purpose of daisy-chaining to other DBK208s or to other P2-supported devices.

DBK209

The DBK209 is a mini-adapter board suitable for both analog and digital expansion. The board provides three DB37 connectors (P1, P2, and P3).

DBK209 connects to DaqBoard/2000 Series or /2000c Series P4 connector via a CA-195 cable.

Other than the form factor, DBK209 is identical to DBK201.

- P1 is used for ANALOG I/O.
- P2 is used for DIGITAL I/O.
- P3 is used for Pulse/Frequency (Digital and Counter/Timer) I/O.

DBK209's P4 (100-pin connector) connects to the DaqBoard/2000 Series or /2000c Series board's P4 connector via a CA-195 Cable.

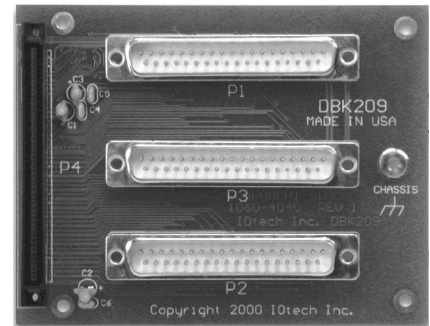

DBK209

P4-to-P1/P2/P3 Mini-adapter Board

Pinouts for DaqBoard/2000 Series and /2000c Series Boards



Reference Notes: You must set up *DaqView* for the particular DBKs in your system. If you are unfamiliar with the method of setting up DBKs in *DaqView*, or if you need a refresher, refer to the following documents as needed.

- The [DBK Set Up in DaqView](#) chapter of the *DBK Option Cards Modules User's Manual* (p/n 457-0905),
- The *DBK Option Cards Modules User's Manual* (p/n 457-0905), for the applicable DBK document module(s). The documentation discusses hardware configuration aspects that require setup in software.
- The [DaqView](#) document module.

During software installation, documentation is automatically installed onto your hard drive as a part of product support. The default location is the **Programs** directory, which can be accessed through the Windows Desktop.

Note: As new DBKs become available, be sure to use the latest revision of *DaqView* with the proper configuration options.

CAUTION



Do not confuse connectors. Ensure that you only connect P1 I/Os to P1, P2 I/Os to P2, and P3 I/Os to P3. Improper connection may result in equipment damage.

The following P1, P2, and P3 connector pinouts pertain to the DBK200 Series adapter boards that were discussed in the first part of this chapter. P1, P2, and P3 are subset connectors of the 100-pin P4 connector found on the DaqBoard/2000 Series and /2000c Series boards, and for that reason P4 pin-correlation is provided.

CAUTION



Do not confuse connectors. Ensure that you only connect P1 I/Os to P1, P2 I/Os to P2, and P3 I/Os to P3. Improper connection may result in equipment damage.

Note: In the pinouts that follow, some pins are irrelevant to certain DaqBoards. For example: DaqBoard/2002, /2002c, /2004, and 2004c have no P1 correlation; and for those boards P1 and the associated P4 pins should be ignored. The DaqBoard/2003 and /2003c only relate to P3 and the associated P4 pins; but for these two boards, a DBK205 screw-terminal adapter is typically used (see page 2-3). Note that chapter 1, [Device Systems and Device Overviews](#), contains detailed information that is specific to each board.

P1

The P1 DB37 connector is obtained with the use of one of the following:

- DBK200
- DBK201
- DBK202
- DBK203
- DBK204
- DBK206
- DBK207
- DBK207/CJC
- DBK209

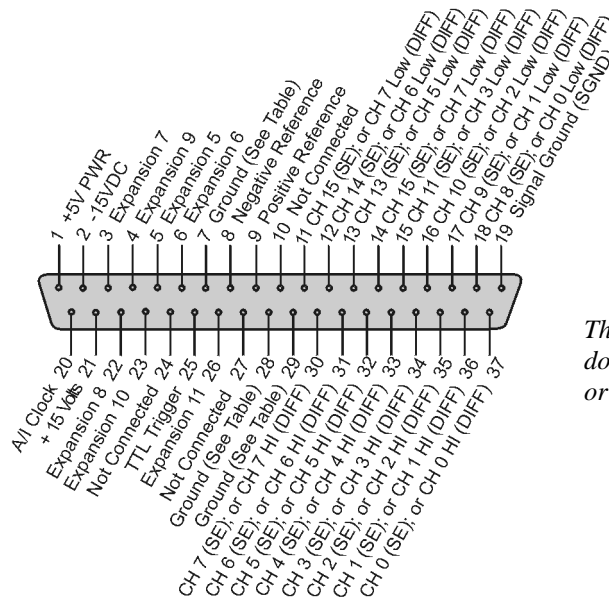

The P1 DB37 connector does not apply to DBK205 or to DBK208.

Pin	Signal Name	Description for P1 Pin Use	P4 Correlation
1	+5 Volts	Expansion +5 V power (Refer to Power Management , chapter 2, in DBK Manual)	A1
2	-15 Volts	Expansion -15 VDC power (Refer to Power Management , ch. 2, in DBK Manual)	A48
3	Expansion 7	Digital OUT, external ADDRESS select bit 3	B32
4	Expansion 9	Digital OUT, external ADDRESS select bit 1	B33
5	Expansion 5	Digital OUT, external GAIN select bit 1	B31
6	Expansion 6	Digital OUT, external GAIN select bit 0	A32
7	Ground	Common See Ground Correlation Tables, page 2-14.	←
8	Negative Reference	Analog, -5 V reference	A36
9	Positive Reference	Analog +5V reference	B35
10	Not Connected	N/A	N/A
11	CH 15 (SE), or CH 7 LO DIFF	Ch 15 HI IN (single-ended mode) / Ch 7 LO IN (differential mode)	B36
12	CH 14 (SE), or CH 6 LO DIFF	Ch 14 HI IN (single-ended mode) / Ch 6 LO IN (differential mode)	A38
13	CH 13 (SE), or CH 5 LO DIFF	Ch 13 HI IN (single-ended mode) / Ch 5 LO IN (differential mode)	B39
14	CH 12 (SE), or CH 4 LO DIFF	Ch 12 HI IN (single-ended mode) / Ch 4 LO IN (differential mode)	A41
15	CH 11 (SE), or CH 3 LO DIFF	Ch 11 HI IN (single-ended mode) / Ch 3 LO IN (differential mode)	B42
16	CH 10 (SE), or CH 2 LO DIFF	Ch 10 HI IN (single-ended mode) / Ch 2 LO IN (differential mode)	A44
17	CH 9 (SE), or CH 1 LO DIFF	Ch 9 HI IN (single-ended mode) / Ch 1 LO IN (differential mode)	B45
18	CH 8 (SE), or CH 0 LO DIFF	Ch 8 HI IN (single-ended mode) / Ch 0 LO IN (differential mode)	A47
19	Signal Ground (SGND)	Sense Common (SGND)	A45
20	A/I Clock	External ADC Pacer Clock Input / Internal ADC Pacer Clock Output	B26
21	+15 Volts	Expansion +15 V power (Refer to Power Management , chapter 2, in DBK Manual)	B48
22	Expansion 8	Digital OUT, external ADDRESS select bit 2	A33
23	Expansion 10	Digital OUT, external ADDRESS select bit 0	A34
24	Not Connected	N/A	N/A
25	TTL Trigger	Digital IN, External TTL Trigger Input	A27
26	Expansion 11	Digital OUT, Simultaneous sample and hold (SSH)	B34
27	Not Connected	N/A	N/A
28	Ground	Common See Ground Correlation Tables, page 2-14.	←
29	Ground	Common See Ground Correlation Tables, page 2-14.	←
30	CH 7 (SE), or CH 7 HI DIFF	Ch 7 IN (single-ended mode) / Ch 7 HI IN (differential mode)	A37
31	CH 6 (SE), or CH 6 HI DIFF	Ch 6 IN (single-ended mode) / Ch 6 HI IN (differential mode)	B38
32	CH 5 (SE), or CH 5 HI DIFF	Ch 5 IN (single-ended mode) / Ch 5 HI IN (differential mode)	A40
33	CH 4 (SE), or CH 4 HI DIFF	Ch 4 IN (single-ended mode) / Ch 4 HI IN (differential mode)	A33, B41
34	CH 3 (SE), or CH 3 HI DIFF	Ch 3 IN (single-ended mode) / Ch 3 HI IN (differential mode)	A43
35	CH 2 (SE), or CH 2 HI DIFF	Ch 2 IN (single-ended mode) / Ch 2 HI IN (differential mode)	B44
36	CH 1 (SE), or CH 1 HI DIFF	Ch 1 IN (single-ended mode) / Ch 1 HI IN (differential mode)	A46
37	CH 0 (SE), or CH 0 HI DIFF	Ch 0 IN (single-ended mode) / Ch 0 HI IN (differential mode)	B47

P2

The P2 DB37 connector is obtained with the use of one of the following:

- DBK201
- DBK202
- DBK203
- DBK204
- DBK206
- DBK208
- DBK209

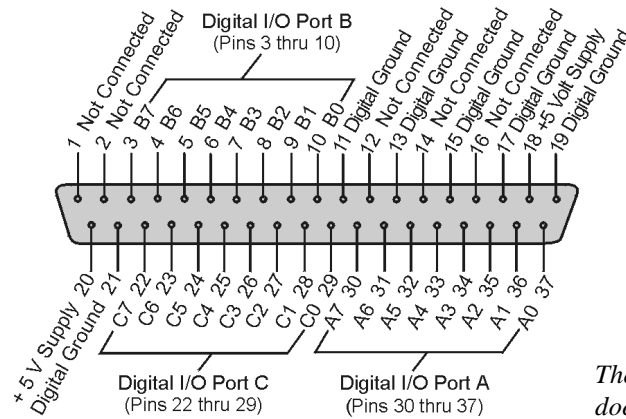

The P2 DB37 connector does not apply to DBK200, DBK205, DBK207, or DBK207/CJC.

Pin	Signal Name	Description for P2 Pin Use	P4 Correlation
1	Not Connected	N/A	N/A
2	Not Connected	N/A	N/A
3	Port B - B7	Digital I/O: P2 Digital Port B, Bit 7; or, P2 Expansion Address Bit 0 Out	B10
4	Port B - B6	Digital I/O: P2 Digital Port B, Bit 6; or, P2 Expansion Address Bit 1 Out	A11
5	Port B - B5	Digital I/O: P2 Digital Port B, Bit 5; or, P2 Expansion Address Bit 2 Out	B11
6	Port B - B4	Digital I/O: P2 Digital Port B, Bit 4; or, P2 Expansion Address Bit 3 Out	A12
7	Port B - B3	Digital I/O: P2 Digital Port B, Bit 3; or, P2 Expansion Address Bit 4 Out	B12
8	Port B - B2	Digital I/O: P2 Digital Port B, Bit 2; or, P2 Expansion RESET Output	A13
9	Port B - B1	Digital I/O: P2 Digital Port B, Bit 1; or, P2 Expansion WRITE Output	B13
10	Port B - B0	Digital I/O: P2 Digital Port B, Bit 0; or, P2 Expansion READ Output	A14
11	Ground	Digital Common See Ground Correlation Tables, page 2- 14.	←
12	Not Connected	N/A	N/A
13	Ground	Digital Common See Ground Correlation Tables, page 2- 14.	←
14	Not Connected	N/A	N/A
15	Ground	Digital Common See Ground Correlation Tables, page 2- 14.	←
16	Not Connected	N/A	N/A
17	Ground	Digital Common See Ground Correlation Tables, page 2- 14.	←
18	+ 5 Volt Supply	Expansion +5 Volt Power (Refer to Power Management , ch. 2, in DBK Manual)	A1, B1
19	Ground	Digital Common See Ground Correlation Tables, page 2- 14.	←
20	+ 5 Volt Supply	Expansion +5 Volt Power (Refer to Power Management , ch. 2, in DBK Manual)	A1, B1
21	Ground	Digital Common See Ground Correlation Tables, page 2- 14.	←
22	Port C - C7	Digital I/O: P2 Digital Port C, Bit 7; or, P2 Expansion Data Bit 7	A6
23	Port C - C6	Digital I/O: P2 Digital Port C, Bit 6; or, P2 Expansion Data Bit 6	B6
24	Port C - C5	Digital I/O: P2 Digital Port C, Bit 5; or, P2 Expansion Data Bit 5	A7
25	Port C - C4	Digital I/O: P2 Digital Port C, Bit 4; or, P2 Expansion Data Bit 4	B7
26	Port C - C3	Digital I/O: P2 Digital Port C, Bit 3; or, P2 Expansion Data Bit 3	A8
27	Port C - C2	Digital I/O: P2 Digital Port C, Bit 2; or, P2 Expansion Data Bit 2	B8
28	Port C - C1	Digital I/O: P2 Digital Port C, Bit 1; or, P2 Expansion Data Bit 1	A9
29	Port C - C0	Digital I/O: P2 Digital Port C, Bit 0; or, P2 Expansion Data Bit 0	B9
30	Port A - A7	Digital I/O: P2 Digital Port A, Bit 7; or, P2 Expansion Data Bit 15	A2
31	Port A - A6	Digital I/O: P2 Digital Port A, Bit 6; or, P2 Expansion Data Bit 14	B2
32	Port A - A5	Digital I/O: P2 Digital Port A, Bit 5; or, P2 Expansion Data Bit 13	A3
33	Port A - A4	Digital I/O: P2 Digital Port A, Bit 4; or, P2 Expansion Data Bit 12	B3
34	Port A - A3	Digital I/O: P2 Digital Port A, Bit 3; or, P2 Expansion Data Bit 11	A4
35	Port A - A2	Digital I/O: P2 Digital Port A, Bit 2; or, P2 Expansion Data Bit 10	B4
36	Port A - A1	Digital I/O: P2 Digital Port A, Bit 1; or, P2 Expansion Data Bit 9	A5
37	Port A - A0	Digital I/O: P2 Digital Port A, Bit 0; or, P2 Expansion Data Bit 8	B5

P3 for DaqBoard/2000 Series and /2000c Series Boards Pulse/Frequency/Digital I/O

P3

The P3 DB37 connector is obtained with the use of one of the following:

- DBK201
- DBK202 (Note 1)
- DBK203 (Note 1)
- DBK204 (Note 1)
- DBK206
- DBK209

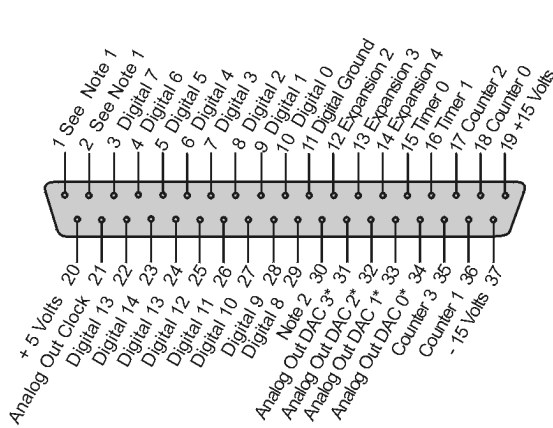

DB37 P3 Connector

Note: There is no direct pin number correlation between the 40-pin header and the DB37 P3 connector.

*In regard to pins 31 through 34, see Note 3.

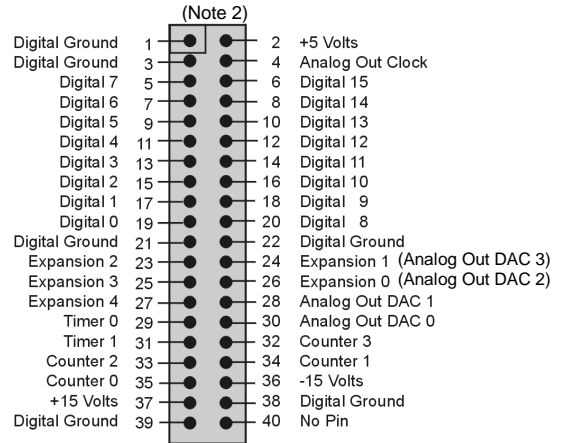

**DBK202, DBK203, DBK204
"On-Board" 40-Pin Header**

The P3 DB37 connector does not apply to DBK200, DBK205, DBK207, DBK207/CJC, or DBK208.

Pin	Signal Name	Description for P3 Pin Use	P4 Correlation
1	Digital Ground (Note 1)	Digital Common See Ground Correlation Tables, page 2-14.	←
2	Digital Ground (Note 1)	Digital Common See Ground Correlation Tables, page 2-14.	←
3	Digital 7	P3 Digital Port Bit 7	B19
4	Digital 6	P3 Digital Port Bit 6	A19
5	Digital 5	P3 Digital Port Bit 5	B20
6	Digital 4	P3 Digital Port Bit 4	A20
7	Digital 3	P3 Digital Port Bit 3	B21
8	Digital 2	P3 Digital Port Bit 2	A21
9	Digital 1	P3 Digital Port Bit 1	B22
10	Digital 0	P3 Digital Port Bit 0	A22
11	Digital Ground	Digital Common See Ground Correlation Tables, page 2-14.	←
12	Expansion 2	Reserved	---
13	Expansion 3	Reserved	---
14	Expansion 4	Reserved	---
15	Timer 0	P3 Timer 0 Output	B24
16	Timer 1	P3 Timer 1 Output	A25
17	Counter 2	P3 Counter 2 Input	B28
18	Counter 0	P3 Counter 0 Input	B29
19	+ 15 Volts	Expansion, +15 VDC	B48
20	+ 5 Volt Supply	Expansion, +5 Volt Power (Refer to Power Management , ch. 2, in DBK Manual)	A1, B1
21	Analog Out Clock	External DAC Pacer Clock Input/Internal DAC Pacer Clock Output	A26
22	Digital 15	Digital I/O; P3 Digital Port Bit 15	B15
23	Digital 14	Digital I/O; P3 Digital Port Bit 14	A15
24	Digital 13	P3 Digital Port Bit 13	B16
25	Digital 12	P3 Digital Port Bit 12	A16
26	Digital 11	P3 Digital Port Bit 11	B17
27	Digital 10	P3 Digital Port Bit 10	A17
28	Digital 9	P3 Digital Port Bit 9	B18
29	Digital 8	P3 Digital Port Bit 8	A18
30	Digital Ground	Digital Common See Ground Correlation Tables, page 2-14.	←
31	Analog Out DAC 3 (Note 3)	Analog DAC 3 Output	B50
32	Analog Out DAC 2 (Note 3)	Analog DAC 2 Output	B49
33	Analog Out DAC 1 (Note 3)	Analog DAC 1 Output	A50
34	Analog Out DAC 0 (Note 3)	Analog DAC 0 Output	A49
35	Counter 3	P3 Counter 3 Input	A28
36	Counter 1	P3 Counter 1 Input	A29
37	- 15 Volts	Expansion, - 15 VDC Power (Refer to Power Management , ch. 2, in DBK Manual)	A48

Note 1: P3 pins 1 and 2 are not connected on DBK201.

Note 2: For DBK202, DBK203, and DBK204, the 37-pin P3 connector is obtained by connecting a CA-60 cable to an "On-Board" 40-pin header.

Note 3: Pins 31, 32, 33, and 34 on the P3 DB37 connector are used for Analog Out DACs. DaqBoard/2001, /2003 & /2004 can utilize all four pins. DaqBoard/2000 does not make use of pins 31 or 32. DaqBoard/2002 and DaqBoard/2005 boards do not make use of pins 31 through 34 as these series two boards have no Analog Out DAC.

P4 to P1, P2 and P3 Correlation

The following table lists the correlation between the P4 I/O lines and their respective P1, P2 and P3 pin locations on the DBK200 Series boards. Ground correlation is provided in a subsequent table.

P4 Pin	Signal	Type	Description	P1, P2, P3 Correlation
A1	+5VDC	Power	Expansion +5 Volts	P1 pin 1 P2 pin 18, 20 P3 pin 20
B1	+5VDC	Power	Expansion +5 Volts	P1 pin 1 P2 pin 18, 20 P3 pin 20
A2	Port A bit 7	Dig I/O	P2 Digital Port A, bit 7 -or- P2 expansion Data bit 15	P2 pin 30
B2	Port A bit 6	Dig I/O	P2 Digital Port A, bit 6 -or- P2 expansion Data bit 14	P2 pin 31
A3	Port A bit 5	Dig I/O	P2 Digital Port A, bit 5 -or- P2 expansion Data bit 13	P2 pin 32
B3	Port A bit 4	Dig I/O	P2 Digital Port A, bit 4 -or- P2 expansion Data bit 12	P2 pin 33
A4	Port A bit 3	Dig I/O	P2 Digital Port A, bit 3 -or- P2 expansion Data bit 11	P2 pin 34
B4	Port A bit 2	Dig I/O	P2 Digital Port A, bit 2 -or- P2 expansion Data bit 10	P2 pin 35
A5	Port A bit 1	Dig I/O	P2 Digital Port A, bit 1 -or- P2 expansion Data bit 9	P2 pin 36
B5	Port A bit 0	Dig I/O	P2 Digital Port A, bit 0 -or- P2 expansion Data bit 8	P2 pin 37
A6	Port C bit 7	Dig I/O	P2 Digital Port C, bit 7 -or- P2 expansion Data bit 7	P2 pin 22
B6	Port C bit 6	Dig I/O	P2 Digital Port C, bit 6 -or- P2 expansion Data bit 6	P2 pin 23
A7	Port C bit 5	Dig I/O	P2 Digital Port C, bit 5 -or- P2 expansion Data bit 5	P2 pin 24
B7	Port C bit 4	Dig I/O	P2 Digital Port C, bit 4 -or- P2 expansion Data bit 4	P2 pin 25
A8	Port C bit 3	Dig I/O	P2 Digital Port C, bit 3 -or- P2 expansion Data bit 3	P2 pin 26
B8	Port C bit 2	Dig I/O	P2 Digital Port C, bit 2 -or- P2 expansion Data bit 2	P2 pin 27
A9	Port C bit 1	Dig I/O	P2 Digital Port C, bit 1 -or- P2 expansion Data bit 1	P2 pin 28
B9	Port C bit 0	Dig I/O	P2 Digital Port C, bit 0 -or- P2 expansion Data bit 0	P2 pin 29
A10	Ground	Dig I/O	Digital Common	See Ground Tables
B10	Port B bit 7	Dig I/O	P2 Digital Port B, bit 7 -or- P2 expansion address bit 0	P2 pin 3
A11	Port B bit 6	Dig I/O	P2 Digital Port B, bit 6 -or- P2 expansion address bit 1	P2 pin 4
B11	Port B bit 5	Dig I/O	P2 Digital Port B, bit 5 -or- P2 expansion address bit 2	P2 pin 5
A12	Port B bit 4	Dig I/O	P2 Digital Port B, bit 4 -or- P2 expansion address bit 2	P2 pin 6
B12	Port B bit 3	Dig I/O	P2 Digital Port B, bit 3 -or- P2 expansion address bit 3	P2 pin 7
A13	Port B bit 2	Dig I/O	P2 Digital Port B, bit 2 -or- P2 expansion RESET	P2 pin 8
B13	Port B bit 1	Dig I/O	P2 Digital Port B, bit 1 -or- P2 expansion WRITE	P2 pin 9
A14	Port B bit 0	Dig I/O	P2 Digital Port B, bit 0 -or- P2 expansion READ	P2 pin 10
B14	Ground	Dig I/O	Digital Common	See Ground Tables

This table is continued.

P4 Pin	Signal	Type	Description	P1, P2, P3 Correlation
A15	P3 Dig bit 14	Dig I/O	P3 Digital Port bit 14	P3 pin 23
B15	P3 Dig bit 15	Dig I/O	P3 Digital Port bit 15	P3 pin 22
A16	P3 Dig bit 12	Dig I/O	P3 Digital Port bit 12	P3 pin 25
B16	P3 Dig bit 13	Dig I/O	P3 Digital Port bit 13	P3 pin 24
A17	P3 Dig bit 10	Dig I/O	P3 Digital Port bit 10	P3 pin 27
B17	P3 Dig bit 11	Dig I/O	P3 Digital Port bit 11	P3 pin 26
A18	P3 Dig bit 8	Dig I/O	P3 Digital Port bit 8	P3 pin 29
B18	P3 Dig bit 9	Dig I/O	P3 Digital Port bit 9	P3 pin 28
A19	P3 Dig bit 6	Dig I/O	P3 Digital Port bit 6	P3 pin 4
B19	P3 Dig bit 7	Dig I/O	P3 Digital Port bit 7	P3 pin 3
A20	P3 Dig bit 4	Dig I/O	P3 Digital Port bit 4	P3 pin 6
B20	P3 Dig bit 5	Dig I/O	P3 Digital Port bit 5	P3 pin 5
A21	P3 Dig bit 2	Dig I/O	P3 Digital Port bit 2	P3 pin 8
B21	P3 Dig bit 3	Dig I/O	P3 Digital Port bit 3	P3 pin 7
A22	P3 Dig bit 0	Dig I/O	P3 Digital Port bit 0	P3 pin 10
B22	P3 Dig bit 1	Dig I/O	P3 Digital Port bit 1	P3 pin 9
A23	Ground	Dig I/O	Digital Common	See Ground Tables
B23	XCK	Dig I/O	Reserved	No Connection
A24	Ground	Dig I/O	Digital Common	See Ground Tables
B24	Timer 0	Dig OUT	P3 Timer 0 Output	P3 pin 15
A25	Timer 1	Dig OUT	P3 Timer 1 Output	P3 pin 16
B25	Ground	Dig I/O	Digital Common	See Ground Tables
A26	DAC Pacer	Dig I/O	External DAC Pacer Clock Input / Internal DAC Pacer Output	P3 pin 21
B26	ADC Pacer	Dig I/O	External ADC Pacer Clock Input / Internal ADC Pacer Output	P1 pin 20
A27	TTL Trigger	Dig IN	External TTL Trigger Input	P1 pin 25
B27	Ground	Dig I/O	Digital Common	See Ground Tables
A28	Counter 3	Dig IN	P3 Counter 3 Input	P3 pin 35
B28	Counter 2	Dig IN	P3 Counter 2 Input	P3 pin 17
A29	Counter 1	Dig IN	P3 Counter 1 Input	P3 pin 36
B29	Counter 0	Dig IN	P3 Counter 0 Input	P3 pin 18
A30	CD ACK-	Dig IN	Reserved	No Connection
B30	SDI	Dig IN	Reserved	No Connection
A31	Ground	Analog	Analog Signal Common	See Ground Tables
B31	XI/O Gain 1	Dig OUT	Analog Expansion Gain Select bit 1	P1 pin 5
A32	XI/O Gain 0	Dig OUT	Analog Expansion Gain Select bit 0	P1 pin 6
B32	XI/O Address 3	Dig OUT	Analog Exp. Address Select bit 3	P1 pin 3
A33	XI/O Address 2	Dig OUT	Analog Exp. Address Select bit 2	P1 pin 22
B33	XI/O Address 1	Dig OUT	Analog Exp. Address Select bit 1	P1 pin 4
A34	XI/O Address 0	Dig OUT	Analog Exp. Address Select bit 0	P1 pin 23
B34	External SSH	Dig OUT	Analog Expansion Simultaneous Sample/Hold Signal	P1 pin 26
A35	Ground	Analog	Analog Signal Common	See Ground Tables
B35	Positive Ref	Analog	Analog +5 Volt Reference	P1 pin 9
A36	Negative Ref	Analog	Analog -5 Volt Reference	P1 pin 8
B36	Analog In Ch15	Analog	Analog Input Chan 15 (SE) Analog Input Chan 7L (DIF)	P1 pin 11
A37	Analog In Ch7	Analog	Analog Input Chan 7 (SE) Analog Input Chan 7H (DIF)	P1 pin 30
B37	Ground	Analog	Analog Signal Common	See Ground Tables
A38	Analog In Ch14	Analog	Analog Input Chan 14 (SE) Analog Input Chan 6L (DIF)	P1 pin 12
B38	Analog In Ch6	Analog	Analog Input Chan 6 (SE) Analog Input Chan 6H (DIF)	P1 pin 31
A39	Ground	Analog	Analog Signal Common	See Ground Tables

This table is continued.

P4 Pin	Signal	Type	Description	P1, P2, P3 Correlation
B39	Analog In Ch13	Analog	Analog Input Chan 13 (SE) Analog Input Chan 5L (DIF)	P1 pin 13
A40	Analog In Ch5	Analog	Analog Input Chan 5 (SE) Analog Input Chan 5H (DIF)	P1 pin 32
B40	Ground	Analog	<i>Analog Signal Common</i>	<i>See Ground Tables</i>
A41	Analog In Ch12	Analog	Analog Input Chan 12 (SE) Analog Input Chan 4L (DIF)	P1 pin 14
B41	Analog In Ch	Analog	Analog Input Chan 4 (SE) Analog Input Chan 4H (DIF)	P1 pin 33
A42	Ground	Analog	<i>Analog Signal Common</i>	<i>See Ground Tables</i>
B42	Analog In Ch11	Analog	Analog Input Chan 11 (SE) Analog Input Chan 3L (DIF)	P1 pin 15
A43	Analog In Ch3	Analog	Analog Input Chan 3 (SE) Analog Input Chan 3H (DIF)	P1 pin 34
B43	Ground	Analog	<i>Analog Signal Common</i>	<i>See Ground Tables</i>
A44	Analog In Ch10	Analog	Analog Input Chan 10 (SE) Analog Input Chan 2L (DIF)	P1 pin 16
B44	Analog In Ch2	Analog	Analog Input Chan 2 (SE) Analog Input Chan 2H (DIF)	P1 pin 35
A45	Signal Ground	Analog	Sense Common (SGND)	P1-19
B45	Analog In Ch9	Analog	Analog Input Chan 9 (SE) Analog Input Chan 1L (DIF)	P1 pin 17
A46	Analog In Ch1	Analog	Analog Input Chan 1 (SE) Analog Input Chan 1H (DIF)	P1 pin 36
B46	Ground	Analog	<i>Analog Signal Common</i>	<i>See Ground Tables</i>
A47	Analog In Ch8	Analog	Analog Input Chan 8 (SE) Analog Input Chan 0L (DIF)	P1 pin 18
B47	Analog In Ch0	Analog	Analog Input Chan 0 (SE) Analog Input Chan 0H (DIF)	P1 pin 37
A48	-15VDC	Power	Expansion -15 Volts	P1 pin 2 P3 pin 37
B48	+15VDC	Power	Expansion +15 Volts	P1 pin 21 P3 pin 19
A49	DAC 0	Analog	DAC 0 Output	P3 pin 34
B49 *	DAC 2	Analog	DAC 2 Output	P3 pin 32
A50	DAC 1	Analog	DAC 1 Output	P3 pin 33
B50 *	DAC 3	Analog	DAC 3 Output	P3 pin 31

* DAC 2 and DAC 3 (from P4 pins B49 and B50, respectively) only apply to DaqBoard/2001, /2003 /2004 and the equivalent cPCI DaqBoard/2000c Series Boards.

Ground Tables – P4 Pin to P1, P2, and P3 Ground Correlation

Digital Common (DGND)								
P4 Pin	DBK200	DBK201	DBK202 DBK203 DBK204	DBK206	DBK207	DBK208	DBK209	
A10	-----	-----	-----	P1-7	-----	-----	P1-7	P1
B14	-----	P2-11	P2-11	P2-11	-----	P2-11	P2-11	P2
A23		P2-13	P2-13	P2-13		P2-13	P2-13	
A24		P2-15	P2-15	P2-15		P2-15	P2-15	
B25		P2-17	P2-17	P2-17		P2-17	P2-17	
B27		P2-19	P2-19	P2-19		P2-19	P2-19	
		P2-21	P2-21	P2-21		P2-21	P2-21	
	-----	-----	P3-1	P3-1	-----	-----	P3-1	P3
		-----	P3-2	P3-2			P3-2	
		P3-11	P3-11	P3-11			P3-11	
		-----	P3-30	P3-30			P3-30	

Analog Common (AGND)								
P4 Pin	DBK200	DBK201	DBK202 DBK203 DBK204	DBK206	DBK207	DBK208	DBK209	
A31	P1-7	P1-7	P1-7	-----	P1-7	-----	-----	P1
A35	P1-28	P1-28	P1-28	P1-28	P1-28		P1-28	
B37	P1-29	P1-29	P1-29	P1-29	P1-29		P1-29	
A39	-----	-----	-----	-----	-----	-----	-----	P2
B40	-----	P3-30	-----	-----	-----	-----	-----	P3
A42								
B43								
B46								

[Overview3-1](#)
[CE Standards and Directives 3-1](#)
[Safety Conditions3-2](#)
[Emissions/Immunity Conditions3-2](#)
[CE Enhancements for DBKs 3-3](#)
[CE Cable Kits for DaqBoard 2000 Series and /2000c Series Boards..... 3-3](#)

Overview

CE standards were developed by the European Union (EU) dating from 1985 and include specifications both for safety and for EMI emissions and immunity. Now, all affected products sold in EU countries must meet such standards. Although not required in the USA, these standards are considered good engineering practice since they enhance safety while reducing noise and ESD problems.

In contracted and in-house testing, most Daq* products met the required specifications. Those products not originally in compliance were redesigned accordingly. In some cases, alternate product versions, shield plates, edge guards, special connectors, or add-on kits are required to meet CE compliance.



CE-compliant products bear the “CE” mark and include a *Declaration of Conformity* stating the particular specifications and conditions that apply. The test records and supporting documentation that validate the compliance are kept on file at the factory.

CE Standards and Directives

The electromagnetic compatibility (EMC) directives specify two basic requirements:

1. The device must not interfere with radio or telecommunications.
2. The device must be immune from electromagnetic interference from RF transmitters, etc.

The standards are published in the *Official Journal of European Union* under direction of CENELEC (European Committee for Electrotechnical Standardization). The specific standards relevant to Daq* equipment are listed on the product’s Declaration of Conformity and include: CISPR22:1985; EN55022:1988 (Information Technology Equipment, Class A for commercial/industrial use); and EN50082-1:1992 for various categories of EMI immunity.

The safety standard that applies to Daq* products is EN 61010-1 : 1993 (*Safety Requirements for Electrical Equipment for Measurement, Control, and Laboratory Use, Part 1: General Requirements*).

Environmental conditions include the following:

- indoor use
- altitude up to 2000 m
- temperature 5°C to 40°C (41°F to 104°F)
- maximum relative humidity 80% for temperatures up to 31°C (87.8°F) decreasing linearly to 50% relative humidity at 40°C (104°F)
- mains supply voltage fluctuations not to exceed ±10% of the nominal voltage
- other supply voltage fluctuations as stated by the manufacturer
- transient overvoltage according to installation categories (overvoltage categories) I, II and III
For mains supply, the minimum and normal category is II
- pollution degree I or II in accordance with IEC 664

For clarification, terms used in some Declarations of Conformity include:

- **pollution degree:** any addition of foreign matter, solid, liquid or gaseous (ionized gases) that may produce a reduction of dielectric strength or surface resistivity. **Pollution Degree I** has no influence on safety and implies: the equipment is at operating temperature with non-condensing humidity conditions; no conductive particles are permitted in the atmosphere; warm-up time is sufficient to avert any condensation or frost; no hazardous voltages are applied until completion of the warm-up period. **Pollution Degree II** implies the expectation of occasional condensation.
- **overvoltage (installation) category:** classification with limits for transient overvoltage, dependent on the nominal line voltage to earth. **Category I** implies signals without high transient values. **Category II** applies to typical mains power lines with some transients.

Safety Conditions

Users must comply with all relevant safety conditions in the user's manual and the Declarations of Conformity. This manual and Daq* hardware make use of the following Warning and Caution symbols: If you see either of these symbols on a product, carefully read the related information and be alert to the possibility of personal injury.



This warning symbol is used in this manual or on the equipment to warn of possible injury or death from electrical shock under noted conditions.



This warning/caution symbol is used to warn of possible personal injury or equipment damage under noted conditions.

Daq* products contain no user-serviceable parts; refer all service to qualified personnel. The specific safety conditions for CE compliance vary by product; but general safety conditions include:

- The operator must observe all safety cautions and operating conditions specified in the documentation for all hardware used.
- The host computer and all connected equipment must be CE compliant.
- All power must be off to the device and externally connected equipment before internal access to the device is permitted.
- Isolation voltage ratings: do not exceed documented voltage limits for power and signal inputs. All wire insulation and terminal blocks in the system must be rated for the isolation voltage in use. Voltages above 30 Vrms or ± 60 VDC must not be applied if any condensation has formed on the device.
- Current and power use must not exceed specifications. Do not defeat fuses or other over-current protection.

Emissions/Immunity Conditions

The specific immunity conditions for CE compliance vary by product; but general immunity conditions include:

- Cables must be shielded, braid-type with metal-shelled connectors. Input terminal connections are to be made with shielded wire. The shield should be connected to the chassis ground with the hardware provided.
- The host computer must be properly grounded.
- In low-level analog applications, some inaccuracy is to be expected when I/O leads are exposed to RF fields or transients over 3 or 10 V/m as noted on the Declaration of Conformity.

CE Enhancements for DBKs

The following CE enhancements are described in the individual document modules of the *DBK Cards and Modules User's Manual* (p/n 457-0905).

- DBK41/CE
- Edge Guard (for DBK5, DBK8, and DBK44)
- Applicable cables and connectors

CE Cable Kits for DaqBoard 2000 Series and /2000c Series Boards

CAUTION



Turn OFF the power to, and UNPLUG the host PC and externally connected equipment prior to removing the PC's cover and removing (or installing) the DaqBoard/2000 Series [or /2000c Series] Board. Electric shock or damage to equipment can result even under low-voltage conditions.



Take ESD precautions (packaging, proper handling, grounded wrist strap, etc.)

Use care to avoid touching board surfaces and onboard components. Only handle boards by their edges (or ORBs, if applicable). Ensure boards do not come into contact with foreign elements such as oils, water, and industrial particulate.

Note: The CE Cable Kit used with DaqBoard/2000 Series Boards is p/n CA-209.

The CE Cable Kit used with cPCI DaqBoard/2000c Series Boards is p/n CA-209c.

By following these instructions correctly, your DaqBoard/2000 Series [or /2000c Series] Board will be CE Compliant in accordance with the conditions stated on your board's Declaration of Conformity.

If your board is already installed, you will need to remove it from the PC before proceeding. If your board is not yet installed, proceed to the section entitled, *Install the CE ORB*.

Remove DaqBoard/2000 Series or /2000c Series Board from the Host PC

For DaqBoard/2000 Series Boards [PCI type]

1. Turn the host PC's power **OFF**.
2. Turn **power OFF** to externally connected equipment.
3. **UNPLUG the host PC** and all externally connected equipment.
4. Remove the PC's cover. *Refer to your PC Owner's Manual as needed.*
5. Locate the DaqBoard/2000 Series Board and carefully remove the board from its PCI slot.

For cPCI DaqBoard/2000c Series Boards [cPCI Type]

1. Turn the compact PC's power **OFF**.
2. Turn **power OFF** to externally connected equipment.
3. **UNPLUG the compact PC** and all externally connected equipment.
4. Loosen the upper and lower lock screws (see figure).
5. Push the cPCI board's *injector/ejector* down to disengage the board.
6. Slide the board free of the compact PC.

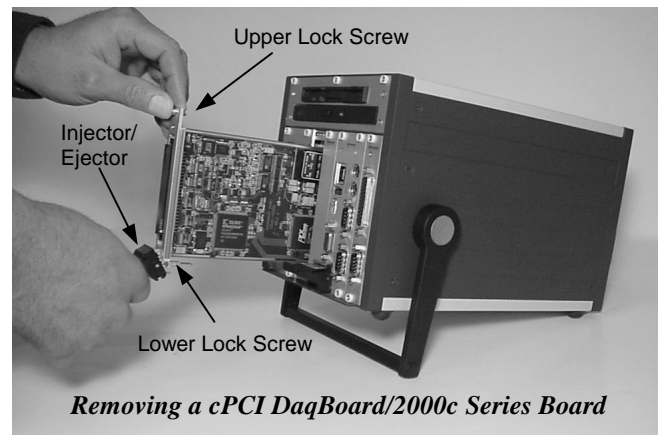

Install the CE ORB

1. Remove the two screws that secure the standard [non-CE] ORB to the board (see figures).
2. Using the same screws, mount the CE ORB to the board. Tighten the screws snug, but do not over tighten.

Note: For the cPCI DaqBoard/2000c Series Boards, the board's edge will locate between the ORB's Retaining Edge and the two screw mounts.

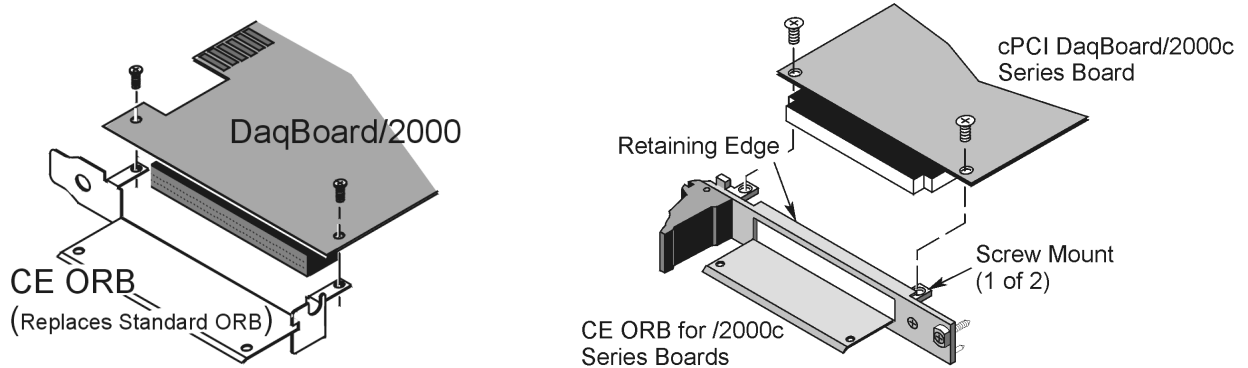

Mounting DaqBoard/2000 Series and cPCI DaqBoard/2000c Series Boards to CE ORBs

Install the Board with its CE ORB

For DaqBoard/2000 Series Boards [PCI type]



If you are installing the DaqBoard/2000 Series Board for the first time, refer to chapter 1 of this manual; or to the DaqBoard/2000 Series Quick Start Guide, prior to installing the board.

1. If you have not already done so, turn **off** power to, and **UNPLUG the host PC** and externally connected equipment. Then remove the PC's cover. Refer to your PC Owner's Manual as needed.
2. Install the DaqBoard/2000 Series Board [with CE ORB] as follows:
 - (a) Align the groove in the edge connector with the ridge on the PCI slot.
 - (b) Push the DaqBoard/2000 Series Board firmly into the PCI slot.
 - (c) Replace the rear panel adapter screw.
3. Replace the PC's cover.

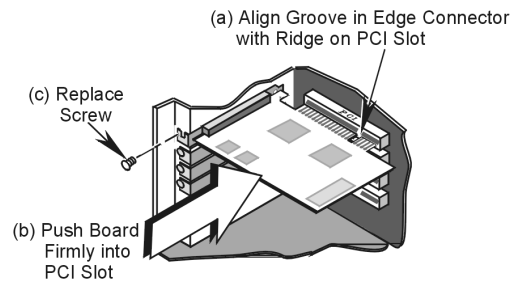

Installing a DaqBoard/2000 Series Board

For cPCI DaqBoard/2000c Series Boards [cPCI Type]



If you are installing the cPCI DaqBoard/2000c Series Board for the first time, refer to chapter 2 of this manual; or to the cPCI DaqBoard/2000c Series Quick Start Guide, prior to installing the board.

1. Turn the compact PC's power **OFF**.
2. Turn **power OFF** to externally connected equipment.
3. **UNPLUG the compact PC** and all externally connected equipment.
4. With the board's *injector/ejector* down, slide the board into the compact PC. Make sure you use the PC's card guides.
5. After the board is inserted, pull the cPCI board's *injector/ejector* up to engage the board.
6. Tighten the upper and lower lock screws.

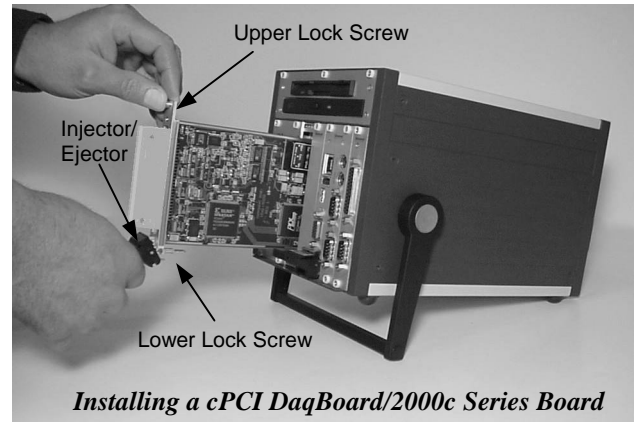

Connect the CA-195CE Cable to the Board

Note: This section includes illustrations depicting the DaqBoard/2000; but apply to both the DaqBoard/2000 Series Boards and the cPCI DaqBoard/2000c Series Boards.

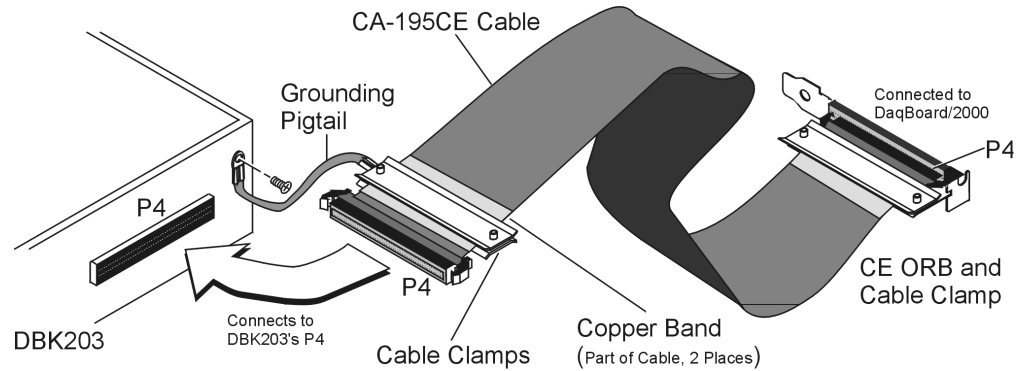

Note: When mating P4 connectors, ensure that the P4 white locator triangles point to each other. The triangles locate pin A1.



1. Connect one end of the CA-195CE Cable to DaqBoard/2000 Series [or /2000c Series] Board's P4 connector. Note that either end of the cable can be connected to the board; however, **the white locator triangles must align with each other**.
2. Align the Cable Clamp (1033-2009) with the CE ORB and secure the items with two 4-40 x 3/16 screws (provided).

Note: In the right hand figure, the cable is not shown to allow for greater clarity of parts.

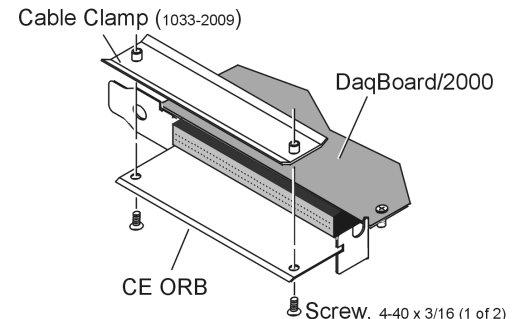

Secure the Grounding Pigtail to Cable CA-195CE

Using Cable Clamps 1033-2009, 1033-2010, and two 4_40 x 5/16 screws, secure the Grounding Pigtail to the cable. Note that the Clamps must be positioned over the cable's Copper Band as shown in the figure on page 3-5. Tighten screws snug, but do not over tighten.

Note: In the following figure, the cable is not shown to allow for greater clarity of parts.

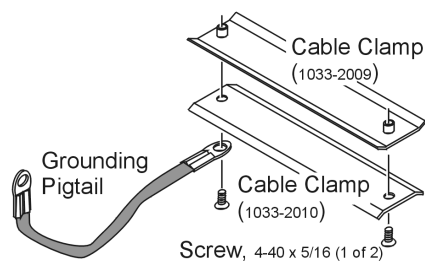

Connect Cable and Grounding Pigtail to DBK203

Note: **DBK204** [for use with DaqBoard/2000 Series Boards] consists of a DBK203 and a CA-209 CE cable kit. **DBK204c** [for use with cPCI DaqBoard/2000c Series Boards] consists of a DBK203 and a CA-209c CE cable kit.

1. Verify correct P4 connector alignment of the CA-195CE Cable and DBK203's P4 connector.
2. Complete the connection.
3. Connect the open end of the Grounding Pigtail to the threaded insert located to the right of DBK203's P4 connector. See figure on page 3-5.

Note: When mating P4 connectors, ensure that the P4 white locator triangles point to each other. The triangles locate pin A1.



At this point your board will be CE compliant, providing that the conditions listed on your board's Declaration of Conformity are satisfied. You can return power to the system and commence with normal operation of your DaqBoard/2000 Series [or /2000c Series] Board.

DaqBoard/2000 Series boards and compact PCI DaqBoard/2000c series boards are factory-calibrated. If adjustments are needed, they should be completed in the following order:

1. PGA Input and Output Offset
2. Sample/Hold Offset
3. A/D Offset and Gain
4. VDC Voltage Reference
5. DAC0 Full-Scale
6. DAC1 Full-Scale

A Windows-based program, DaqCal.exe, is used to calibrate Daq systems, including analog expansion cards. DaqCal.exe is used in conjunction with:

- a 4.5-digit, digital multi-meter
- an adjustable voltage calibrator
- an ambient temperature meter.

To use the calibration program:

1. Launch **DaqCal**.

Note: DaqCal is installed automatically from your data acquisition CD as a part of product support. This takes place during software installation. DaqCal's default location is the **IOtech DaqX Software** folder, in the **Programs** directory.

2. When DaqCal opens you will be prompted to select your device from a list. After doing so, simply follow the illustrated on-screen instructions.



Glossary

Acquisition	A collection of scans acquired at a specified rate as controlled by the sequencer.
Analog	A signal of varying voltage or current that communicates data.
Analog-to-Digital Converter (ADC)	A circuit or device that converts analog values into digital values, such as binary bits, for use in digital computer processing.
API	Application Program Interface. The interface program within the Daq* system's driver that includes function calls specific to Daq* hardware and can be used with user-written programs (several languages supported).
Bipolar	A range of analog signals with positive and negative values (e.g., -5 to +5 V); see <i>unipolar</i> .
Buffer	<p><i>Buffer</i> refers to a circuit or device that allows a signal to pass through it, while providing isolation, or another function, without altering the signal. <i>Buffer</i> usually refers to:</p> <ul style="list-style-type: none">(a) A device or circuit that allows for the temporary storage of data during data transfers. Such storage can compensate for differences in data flow rates. In a FIFO (First In - First Out) buffer, the data that is stored first is also the first data to leave the buffer.(b) A follower stage used to drive a number of gates without overloading the preceding stage.(c) An amplifier which accepts high source impedance input and results in low source impedance output (effectively, an impedance buffer).
Buffer Amplifier	An amplifier used primarily to match two different impedance points, and isolate one stage from a succeeding stage in order to prevent an undesirable interaction between the two stages. (Also see, <i>Buffer</i>).
Channel	<p>In reference to Daq*, <i>channel</i> simply refers to a single <i>input</i>, or <i>output</i> entity.</p> <p>In a broader sense, an <i>input channel</i> is a signal path between the transducer at the point of measurement and the data acquisition system. A channel can go through various stages (buffers, multiplexers, or signal conditioning amplifiers and filters). Input channels are periodically sampled for readings.</p> <p>An <i>output channel</i> from a device can be digital or analog. Outputs can vary in a programmed way in response to an input channel signal.</p>
Common mode	Common mode pertains to signals that are identical in amplitude and duration; also can be used in reference to signal components.
Common mode voltage	Common mode voltage refers to a voltage magnitude (referenced to a common point) that is shared by 2 or more signals. Example: referenced to common, Signal 1 is +5 VDC and Signal 2 is +6 VDC. The common mode voltage for the two signals is +5.5 VDC $[(5 + 6)/2]$.
Crosstalk	An undesired transfer of signals between systems or system components. Crosstalk causes signal interference, more commonly referred to as <i>noise</i> .
Digital	A digital signal is one of discrete value, in contrast to a varying signal. Combinations of binary digits (0s and 1s) represent digital data.

Digital-to-Analog Converter (DAC)	A circuit or device that converts digital values (binary bits), into analog signals.
DIP switch	A DIP switch is a group of miniature switches in a small <i>Dual In-line Package</i> (DIP). Typically, users set these switches to configure their particular application.
Differential mode	The differential mode measures a voltage between 2 signal lines for a single channel. (Also see <i>single-ended mode</i>).
Differential mode voltage	Differential mode voltage refers to a voltage difference between two signals that are referenced to a common point. Example: Signal 1 is +5 VDC referenced to common. Signal 2 is +6 VDC referenced to common. If the +5 VDC signal is used as the reference, the differential mode voltage is +1 VDC (+ 6 VDC - +5 VDC = +1 VDC). If the +6 VDC signal is used as the reference, the differential mode voltage is -1 VDC (+ 5 VDC - +6 VDC = -1 VDC).
ESD	Electrostatic discharge (ESD) is the transfer of an electrostatic charge between bodies having different electrostatic potentials. This transfer occurs during direct contact of the bodies, or when induced by an electrostatic field. ESD energy can damage an integrated circuit (IC); so safe handling is required.
Excitation	Some transducers [e.g. strain gages, thermistors, and resistance temperature detectors (RTDs)] require a known voltage or current. Typically, the variation of this signal through the transducer corresponds to the condition measured.
Gain	The degree to which an input signal is amplified (or attenuated) to allow greater accuracy and resolution; can be expressed as $\times n$ or $\pm dB$.
Isolation	The arrangement or operation of a circuit so that signals from another circuit or device do not affect the <i>isolated</i> circuit. In reference to Daq*, <i>isolation</i> usually refers to a separation of the direct link between the signal source and the analog-to-digital converter (ADC). Isolation is necessary when measuring high common-mode voltage.
Linearization	Some transducers produce a voltage in linear proportion to the condition measured. Other transducers (e.g., thermocouples) have a nonlinear response. To convert nonlinear signals into accurate readings requires software to calibrate several points in the range used and then interpolate values between these points.
Multiplexer (MUX)	A device that collects signals from several inputs and outputs them on a single channel.
Sample (reading)	The value of a signal on a channel at an instant in time. When triggered, the ADC reads the channel and converts the sampled value into a 12- or 16-bit value.
Scan	The channels that are selected for sampling.
Sequencer	A programmable device that manages channels and channel-specific settings.
Simultaneous Sample-and-Hold	An operation that gathers samples from multiple channels at the same instant and holds these values until all are sequentially converted to digital values.
Single-ended mode	The single-ended mode measures a voltage between a signal line and a common reference that may be shared with other channels. (Also see <i>differential mode</i>).

Trigger	An event to start a scan or mark an instant during an acquisition. The event can be defined in various ways; e.g., a TTL signal, a specified voltage level in a monitored channel, a button manually or mechanically engaged, a software command, etc. Some applications may use pre- and post-triggers to gather data around an instant or based on signal counts.
TTL	Transistor-Transistor Logic (TTL) is a circuit in which a multiple-emitter transistor has replaced the multiple diode cluster (of the diode-transistor logic circuit); typically used to communicate logic signals at 5 V.
Unipolar	A range of analog signals that is always zero or positive (e.g., 0 to 10 V). Evaluating a signal in the right range (unipolar or bipolar) allows greater resolution by using the full-range of the corresponding digital value. See <i>bipolar</i> .

